

ME-42

– MistEliminator, 6-step filtration

TECHNICAL DATA

Unit specification

Housing material:

Galvanized steel

Housing finish:

Epoxy powder coat

Unit weight:

117 kg / 257 lbs

Unit dimensions:

H: 1798 mm / 70 ²⁵/₃₂ inch

W: 675 mm / 26 ⁹/₁₆ inch

D: 695 mm / 27 ⁷/₁₆ inch

Air volume:

1200 CFM

Intake velocity:

12 m/s / 2360 fpm

Outlet velocity:

18 m/s / 3540 fpm

Max. negative pressure:

4000 Pa / 16" wg

Oil drain container:

10 litre / 2.6 gal

Filter indicator:

Manometer 0-2000 Pa / 0-8" wg

Filter elements:

Stage 1: Pre separator

Stage 2: Hydro filter (Impinger) – IMP-ME

Stage 3: Pre filter, Aluminium – PF-INL-AL

Stage 4: 16 m²/172.2 ft² Self draining coalescing cassette filter – OC-1

Filter pressure over filter stage 4:

Initial filter pressure over filter stage: 100 Pa / 0.4" wg

Final filter pressure over filter stage: 500 Pa / 4.0" wg

Stage 5: 24 m²/258.3 ft² Self draining coalescing cassette filter – OC-2

Filter pressure over filter stage 5:

Initial filter pressure over filter stage: 100 Pa / 0.4" wg

Final filter pressure over filter stage: 500 Pa / 4.0" wg

Stage 6:

HEPA filter – HFME-3

99.97% ASHRAE/H12 Eurovent

Filter pressure over filter stage 6:

Initial filter pressure over filter stage: 100 Pa / 0.4" wg

Final filter pressure over filter stage: 800 Pa / 2.8" wg

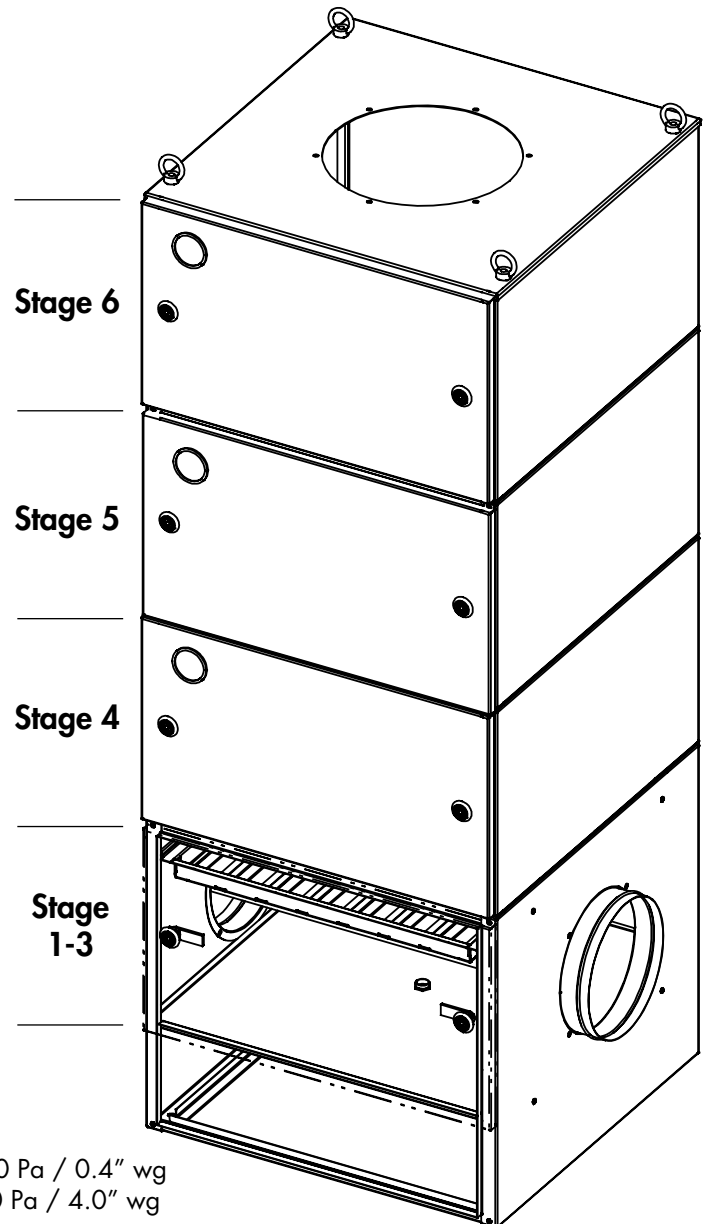

Total filter pressure – for dimensional purpose:
Initial filter pressure over filter: 300 Pa / 1.2" wg
Final filter pressure over filter: 1500 Pa / 6.0" wg

PLYMOVENT[®]
INTELLIGENT PROCESS VENTILATION™

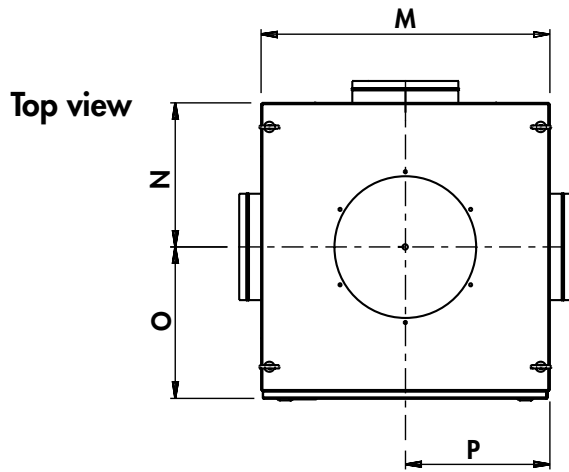
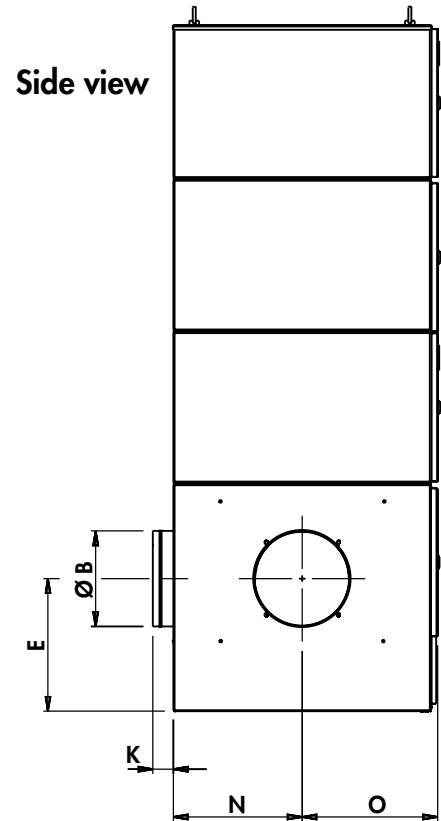
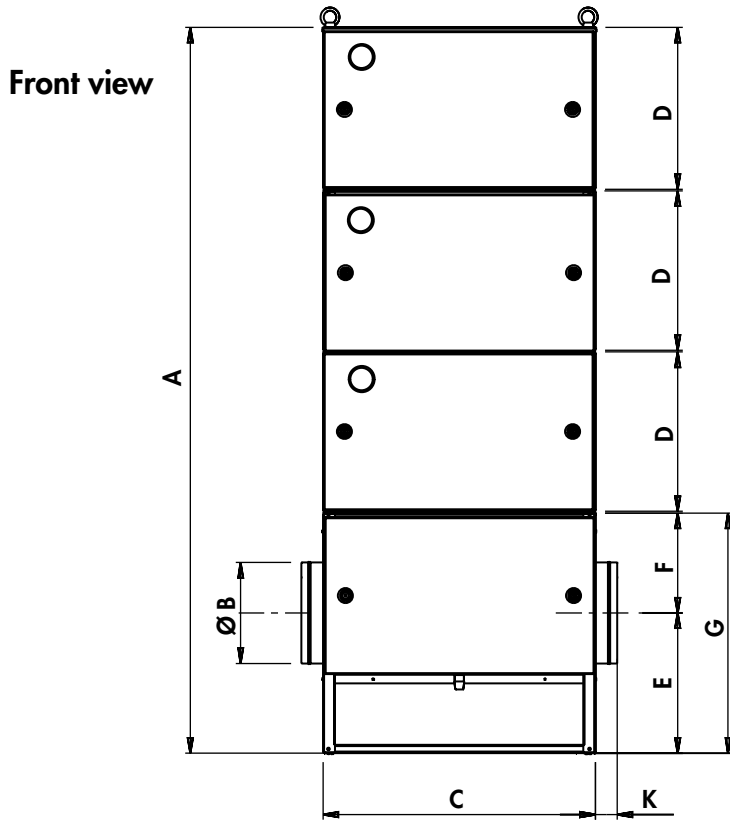

	mm	inch
A	1798	70 25/32
B	250	9 27/32
C	675	26 9/16
D	395	15 9/16
E	347	13 11/16
F	247	9 3/4
G	595	23 7/16
K	53	2 1/8
M	680	26 25/32
N	339	13 3/8
O	356	14 1/32
P	340	13 13/32

PLYMOVENT FAN COLLECTION – QUICKGUIDE

Approx. 4" wg operating pressure
 Approx. 2" wg in duct system
 Velocity approx. 3900 CFM

Please ask for separate information about the complete PlymoVent Fan Collection.

Airvolume	Fan	Airvolume	Fan
900 CFM	FUA-3000	3600 CFM	TEV-745-60
1500 CFM	FUA-4700	6000 CFM	TEV-768-60
2000 CFM	TEV-559-60	8000 CFM	TEV-798-60
2400 CFM	TEV-585-60		