



SHELDONS ENGINEERING Inc.

Sheldons Engineering Product Index

www.sheldonsengineering.com

AIR HANDLING-RADIAL BLADE CENTRIFUGAL FAN – 9000 XB

GENERAL

The centrifugal fan shall be designed and manufactured by Sheldons Engineering to ensure smooth operation. Fan wheel shall be heavy gauge construction with a full back plate and inlet shroud model "XB" as shown in plans with all steel construction. Unless otherwise directed, fan arrangement, motor location, support base, rotation and discharge are as shown on the layout drawings. Fan size is defined as the OD in inches of the fan inlet.

PERFORMANCE

Fan ratings shall be based on tests made in accordance with AMCA Standard 210. Flow shall be actual volumetric flow at the fan inlet. Fan static pressure is defined as static pressure at fan outlet less total pressure at fan inlet. Standard inlet density is to be taken as 0.75 lb/ft³ with corrections for temperature, elevation, inlet static pressure, gas composition and humidity as defined in the schedule. Fans shall be selected to operate to the right of the peak static pressure at the given speed to ensure stable performance. Fan brake horsepower shall rise continuously over the entire range of flows for a given speed and shall be equal to or less than specified at the given flow and fan static pressure.

SOUND

Fan manufacturers shall provide sound power level ratings for fans tested and rated in accordance with AMCA Standards 300 and 301. Sound power ratings shall be in decibels (reference 10-12 watts) in eight octave bands. Sound power levels will be corrected for installation by the specifying engineer...dBA or sound pressure levels only are not acceptable.

CONSTRUCTION

Fan housings are to be heavy -- min. gauge per chart below, continuously welded construction with flanged and punched outlet. Housings with lock seams or spot welded construction are not acceptable.

Fan Size	Class I (12 M)	Class II & III (15 & 19M)	Class IV (22M)
7-11	14 gauge (0.0747" or 1.89 mm)	12 gauge	10 gauge
13-26	12 gauge (0.1046" or 2.66 mm)	10 gauge	7 gauge
29-37	10 gauge (0.1345" or 3.43 mm)	7 gauge	¼"
41-49	7 gauge (0.1875" or 4.76 mm)	¼"	¼"
54-60	---	3/8"	3/8"

BEARINGS (belt driven fans)

Bearings are to be heavy duty, grease lubricated, precision anti-friction, self-aligning pillow block design. Bearings shall be designed for a minimum L₁₀ life per the chart below when rated at the fan's maximum cataloged operating speed.

Class	I	II	III	IV
MIN. L ₁₀ Life	30,000	40,000	100,000	400,000



SHELDONS ENGINEERING Inc.

Sheldons Engineering Product Index

www.sheldonsengineering.com

AIR HANDLING-RADIAL BLADE CENTRIFUGAL FAN –9000

SHAFT (belt driven fans)

Shafts are to be ASTM A-108 steel, grade 1040/1045, precision turned, ground and polished. Grade 1018 steel is not acceptable. The shaft's first critical speed shall be at least 143% of the fan's maximum operating speed.

PAINT

All fan surfaces are to be thoroughly prepared prior to painting using a combination of washing and hand and power tool cleaning as required in SSPC-SP-3. After cleaning, all surfaces are to be coated with a zinc rich oxide primer. Surfaces of bolted components not accessible after assembly shall be coated and allowed to dry prior to final assembly.

BALANCE & INSPECTION

All fans shall be precision balanced to ISO quality grade 2.5, report to be submitted with the maintenance manual. A final inspection by a qualified inspector prior to shipment is required to include: scope of supply confirmation, balance, welding, dimensions, bearings, duct and base connection points, paint finish and overall workmanship.

ACCESSORIES

Accessories shall be provided as called for in the plans and specifications. Standard accessories include:

Motor to be NEMA Design B 3/60/460-575V-1800 rpm, high efficiency TEFC 1.15 SF
V-Belt Drives - Variable Speed/Constant Speed with min 1.5 SF
Belt Guard or weather cover required
Extended lubrication lines (nylon, copper or stainless steel) with fittings terminating in an accessible area.

Additional Features that may be required:

XHD extra heavy duty wheel construction for severe applications
Access Door – bolted/quick opening or plug type with raised door
Housing Drain – pipe ½ coupling or flanged connection
Shaft Seal – non-asbestos fibre or spring loaded carbon ring style
Bolt-on variable inlet vanes
Spark Resistant Construction –
 AMCA “A” All parts in contact with the air stream of Aluminum construction
 AMCA “B” Aluminum wheel with Aluminum rubbing ring around shaft entry point
 AMCA “C” Aluminum inlet cone and Aluminum rubbing ring
Horizontally Split Fan Housing

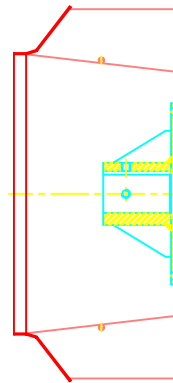
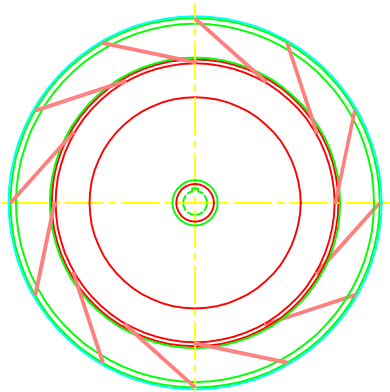
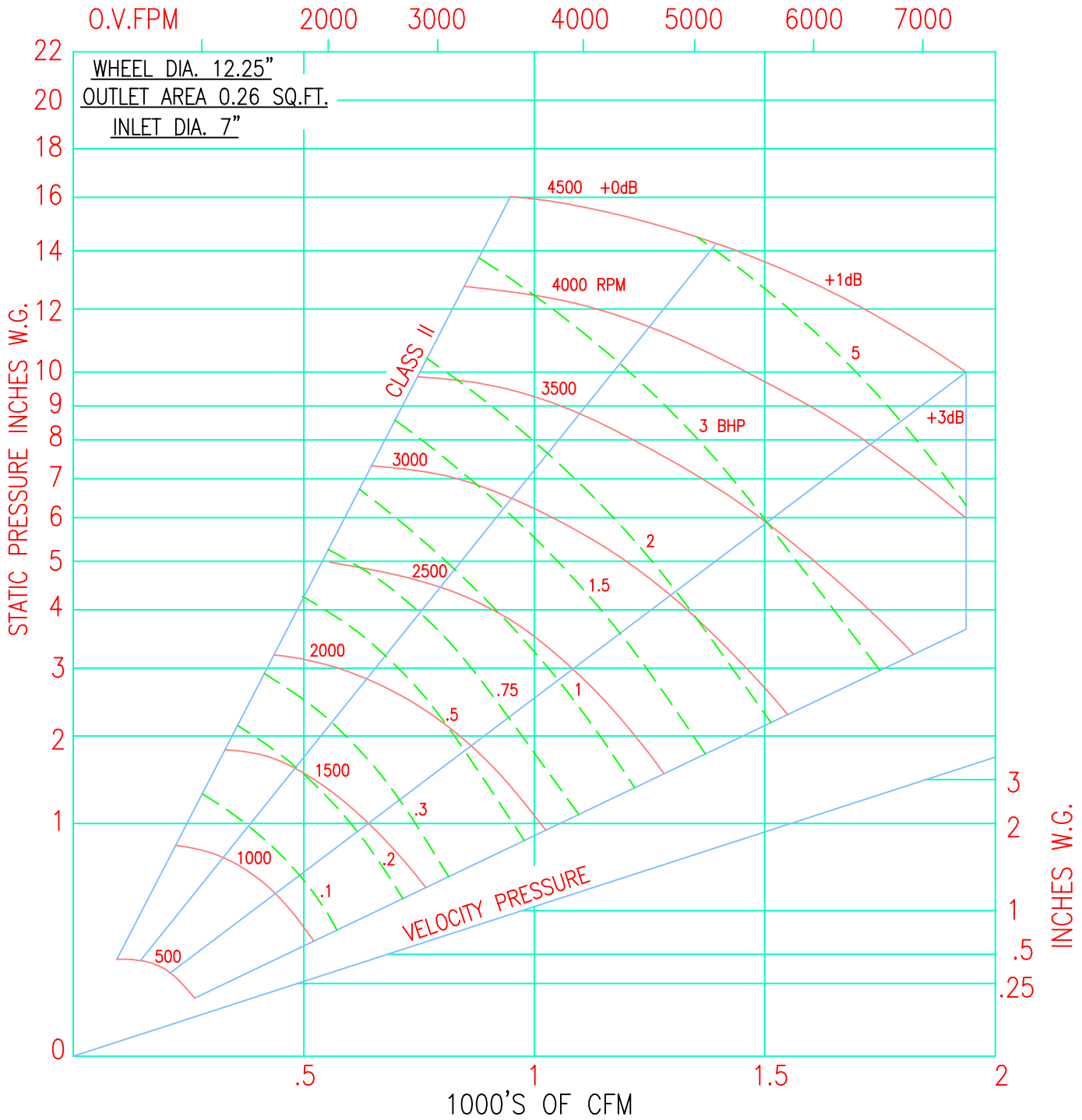

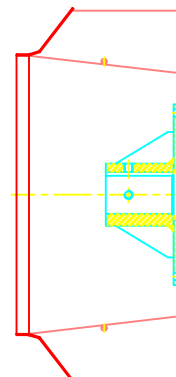
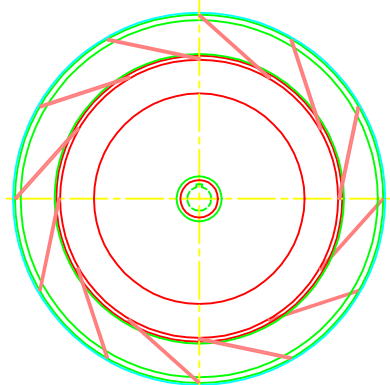
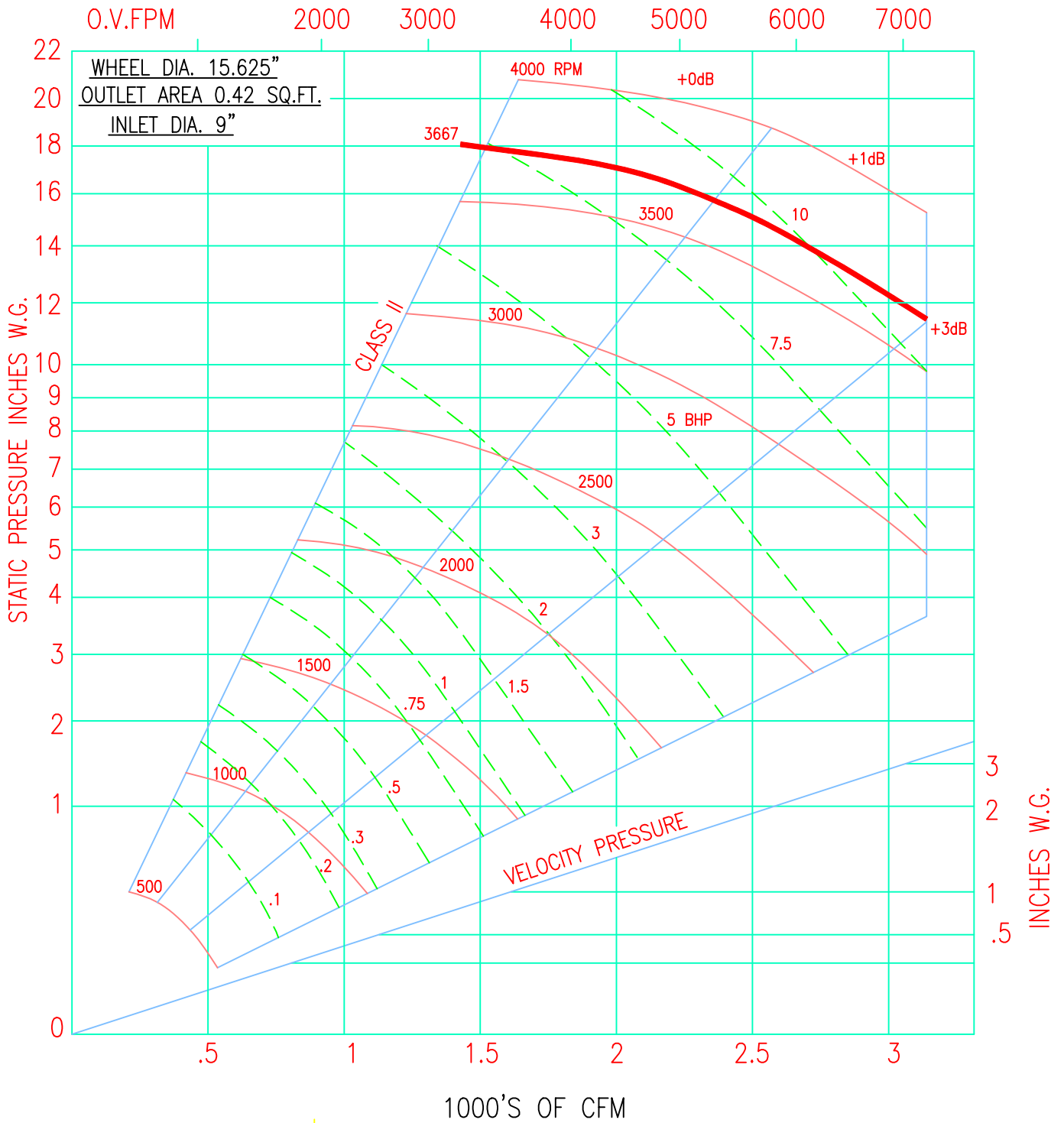

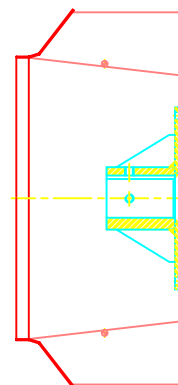
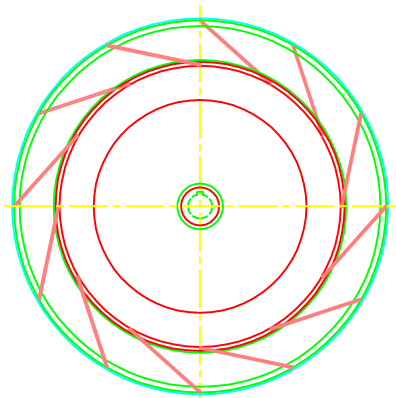
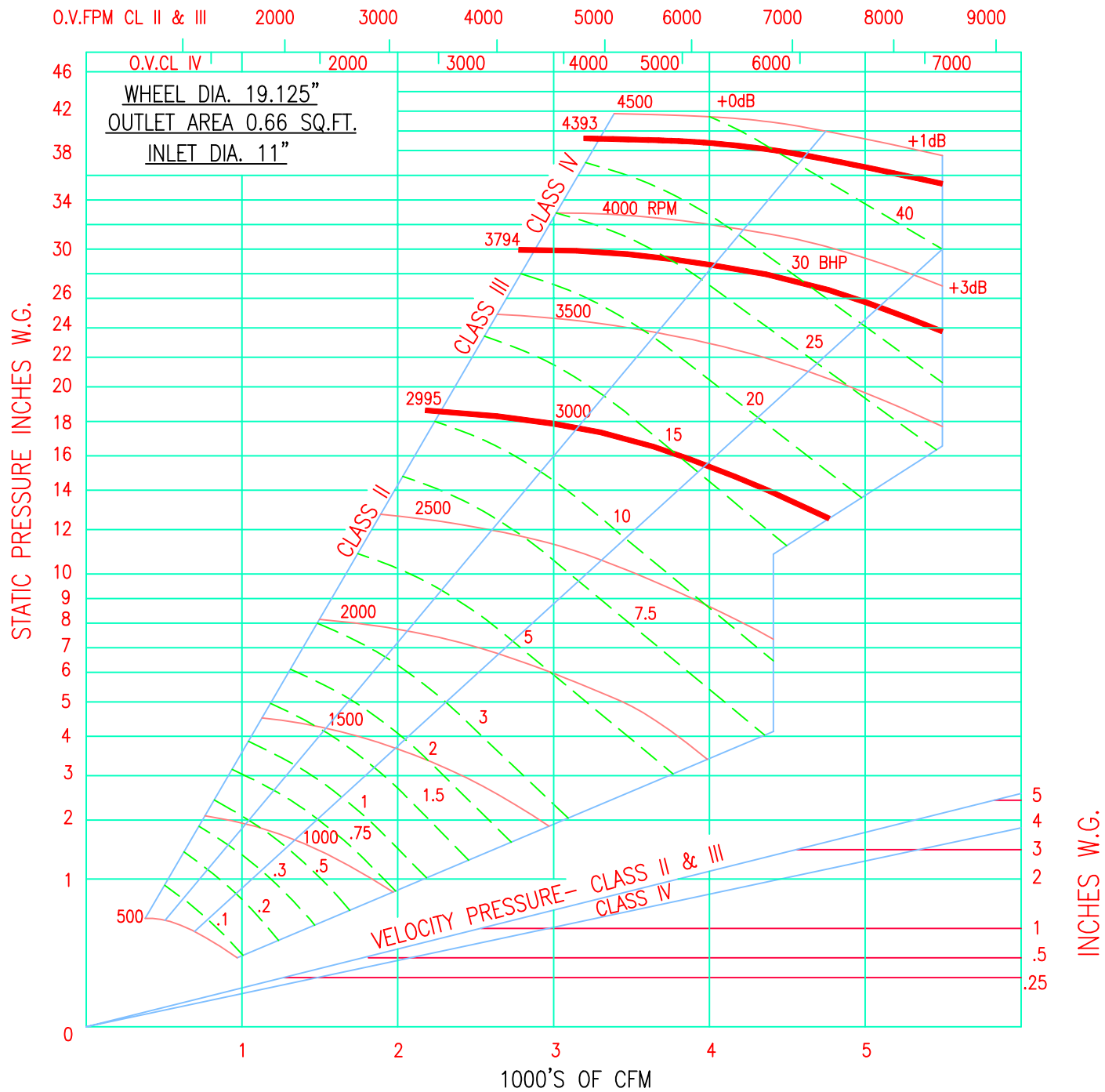

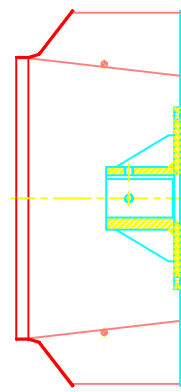
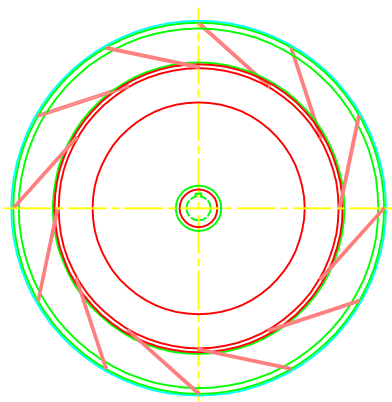
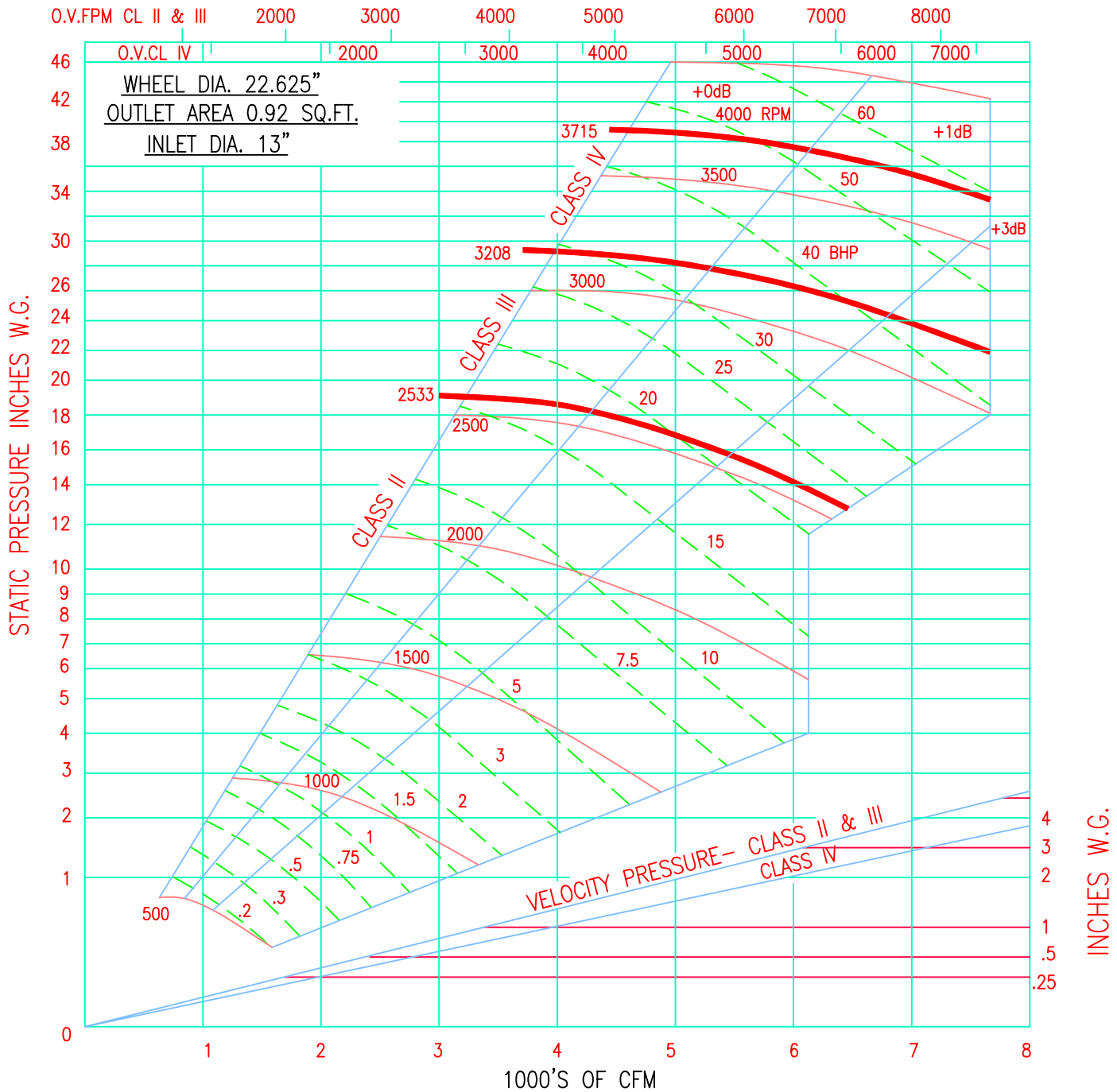

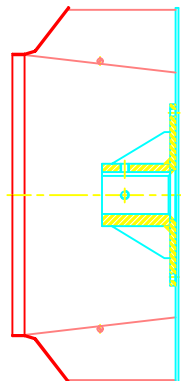
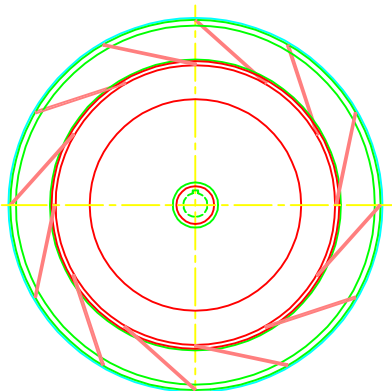
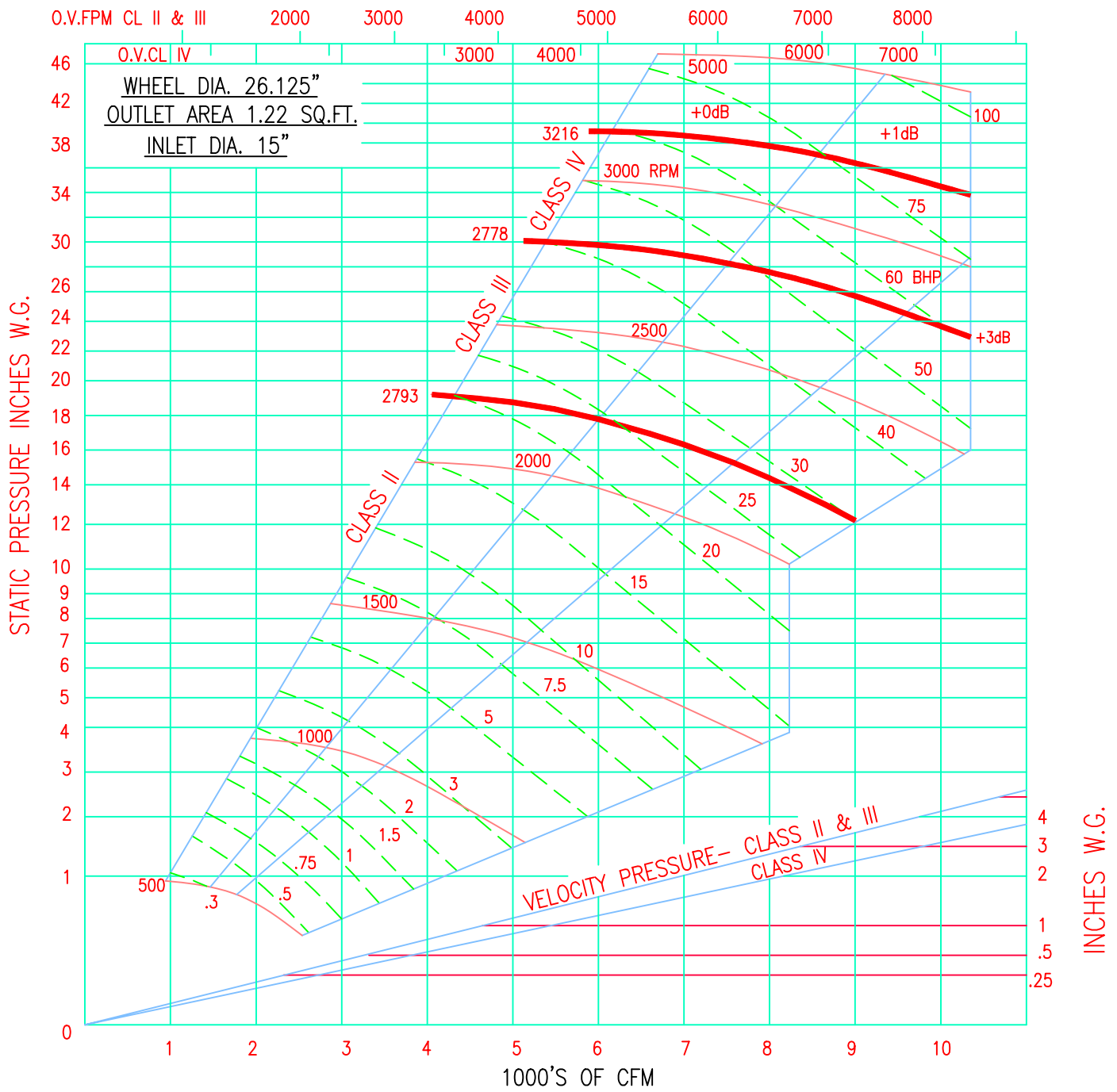

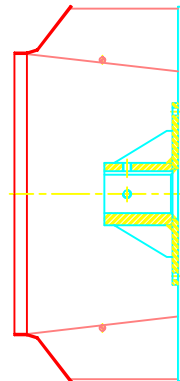
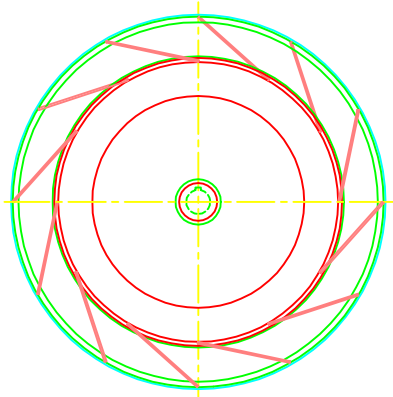
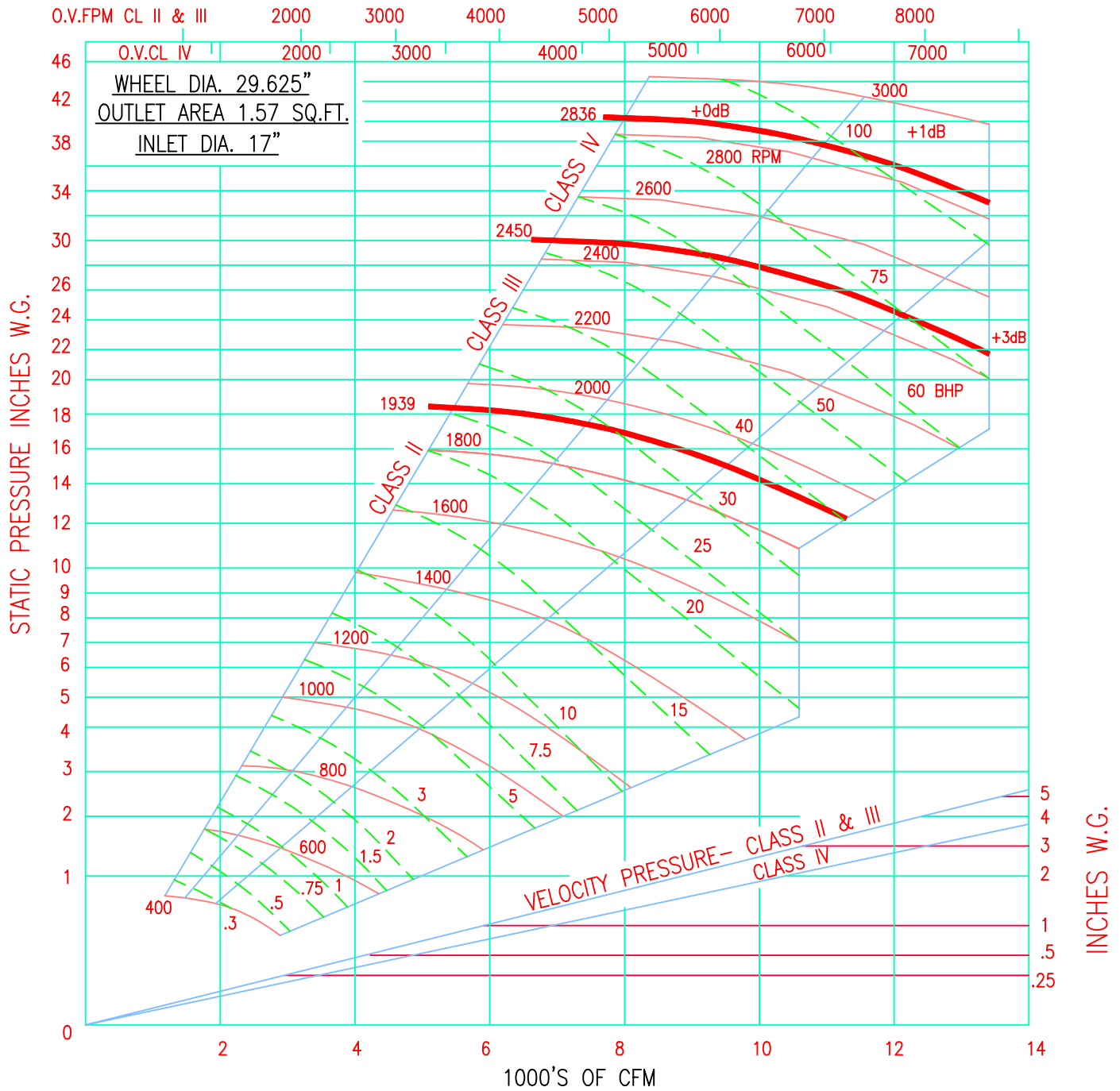

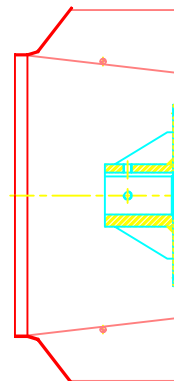
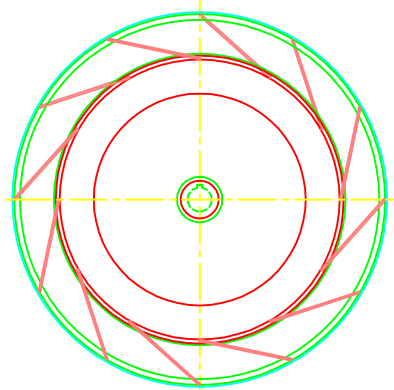
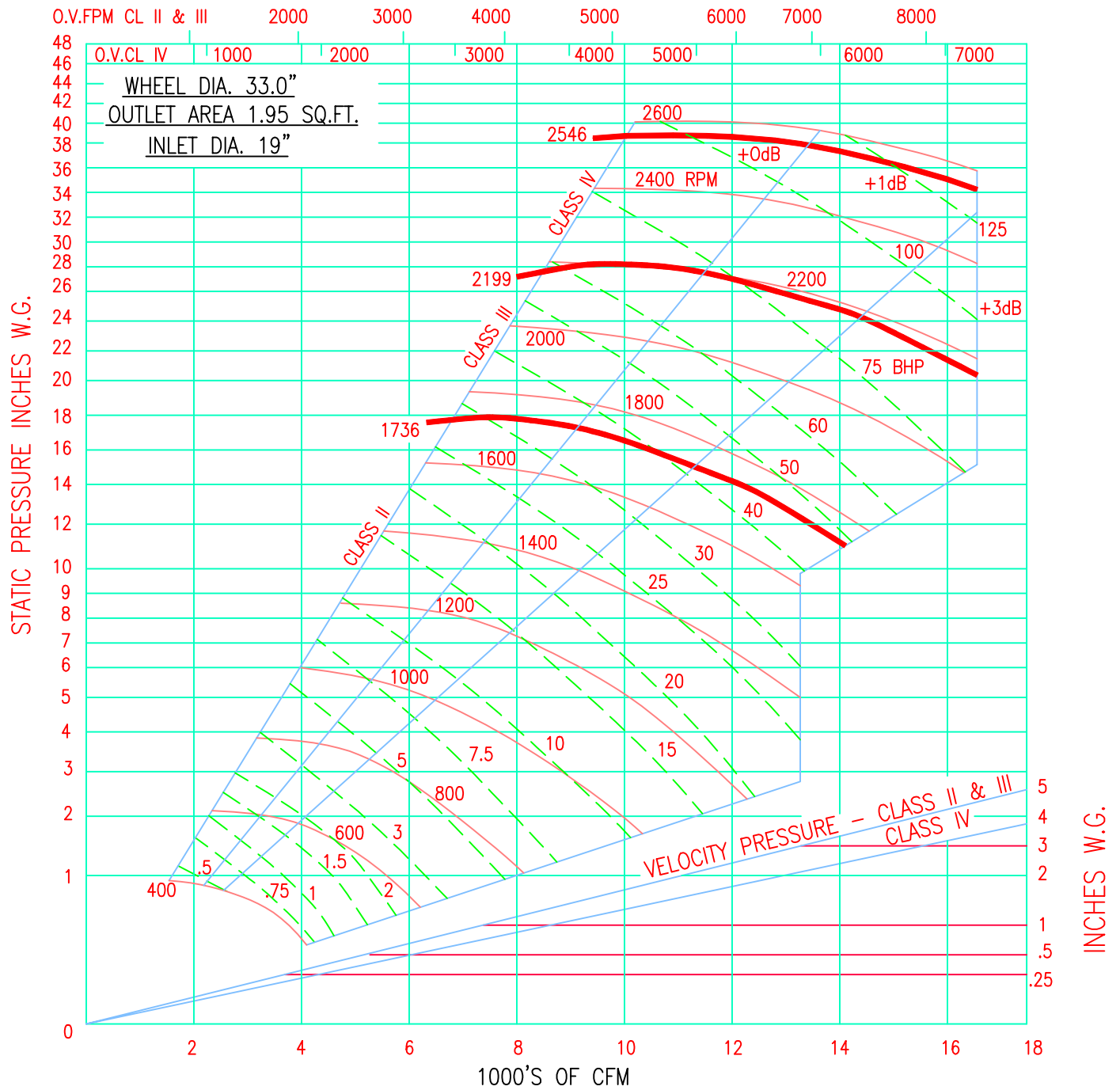

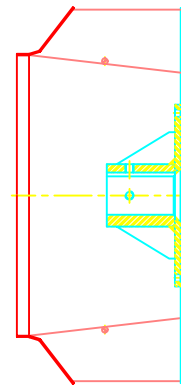
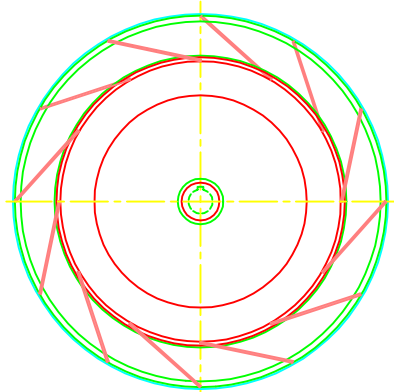
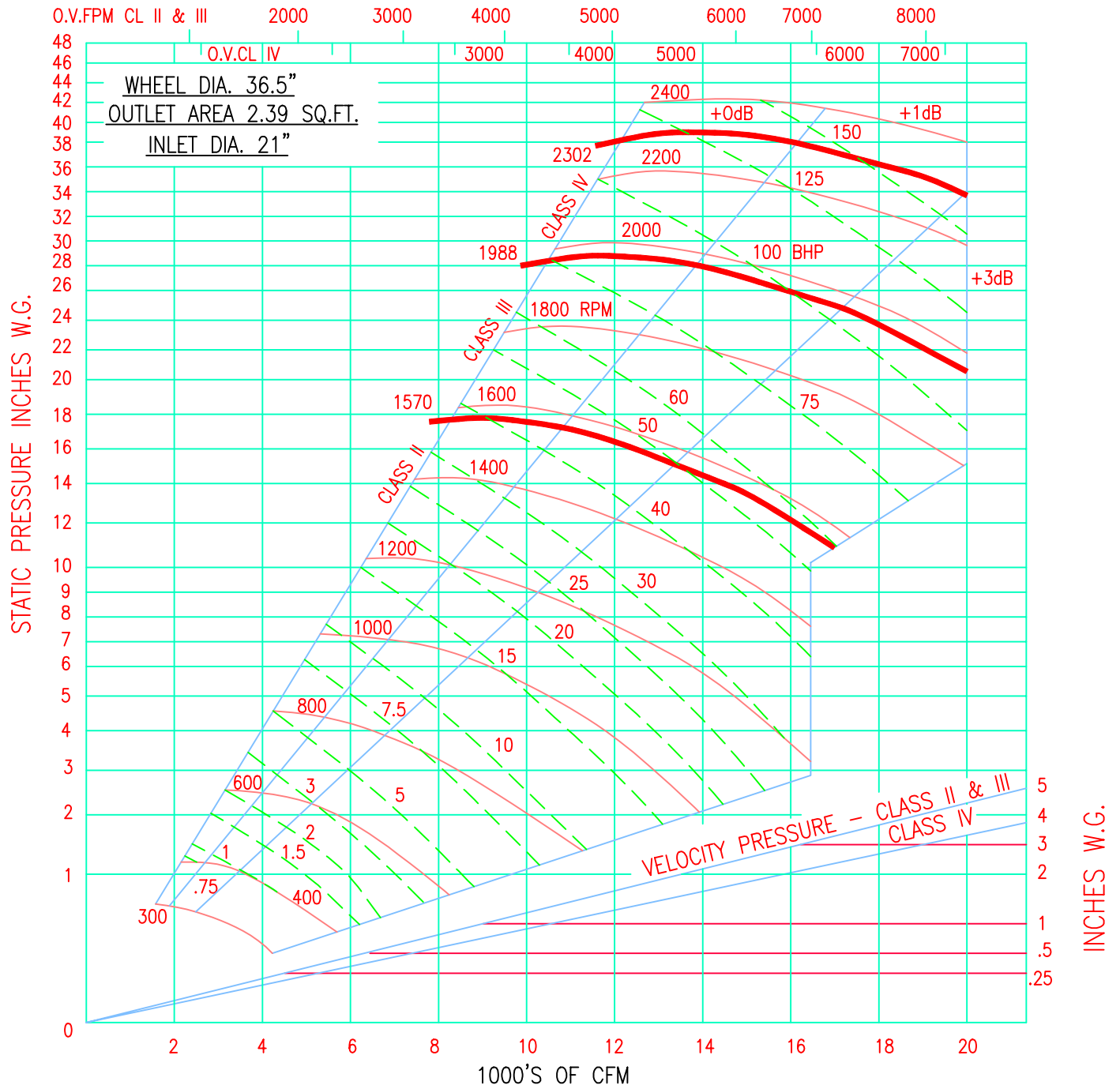

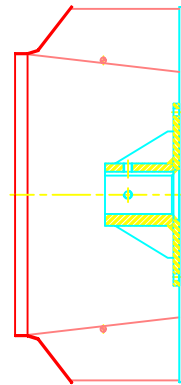
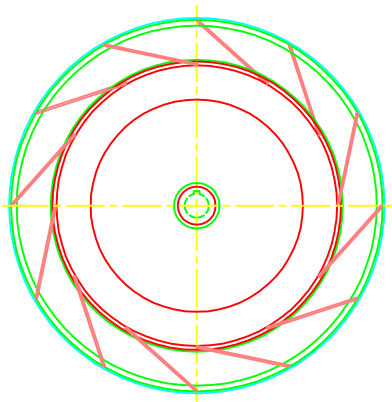
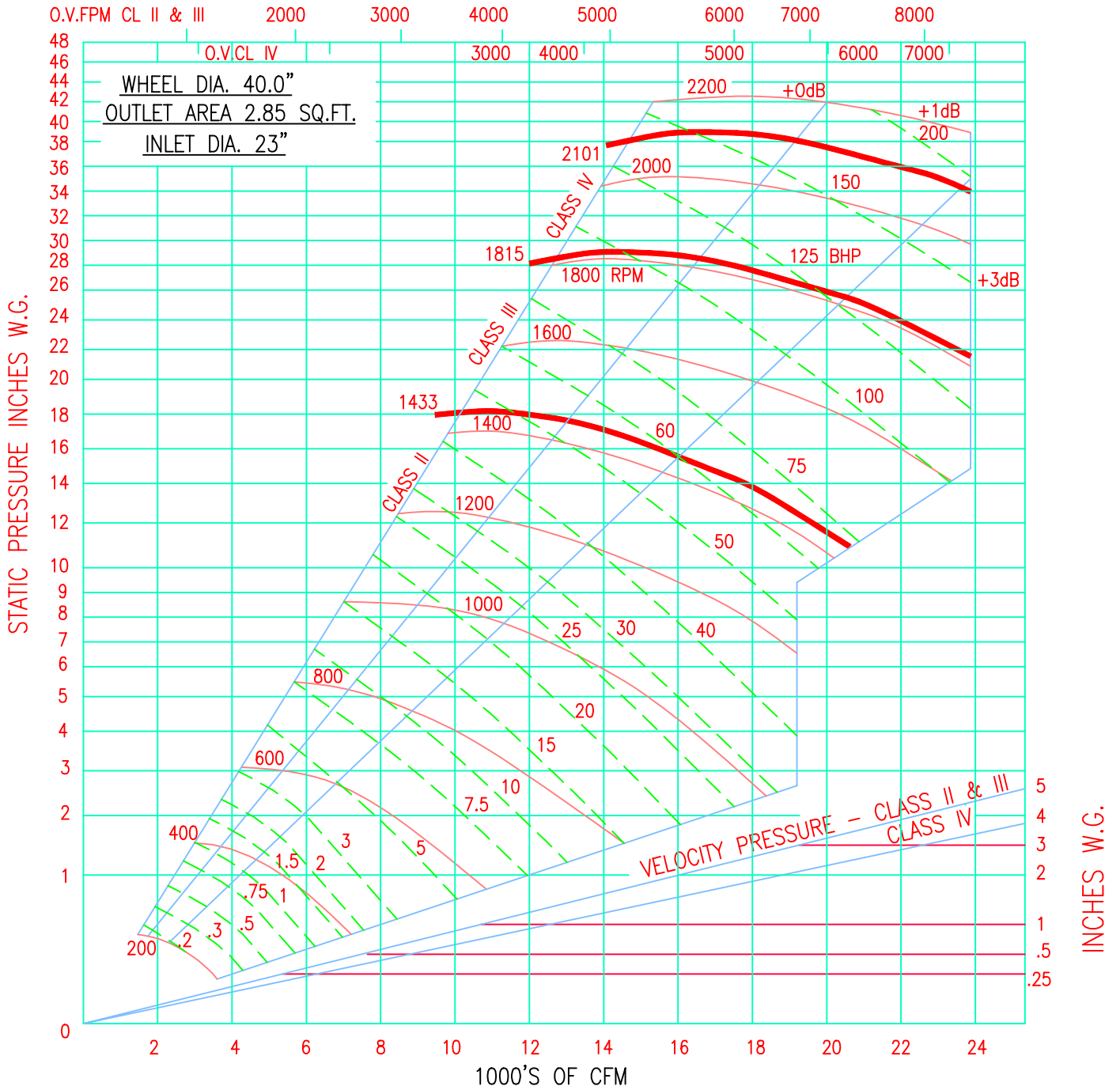

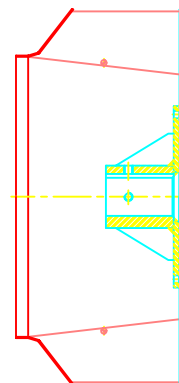
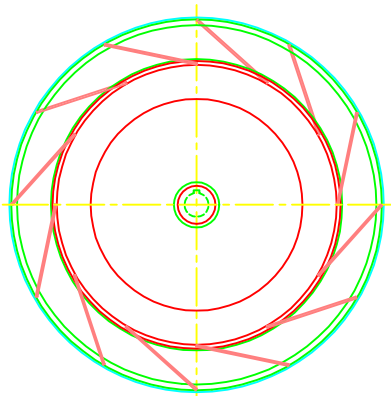
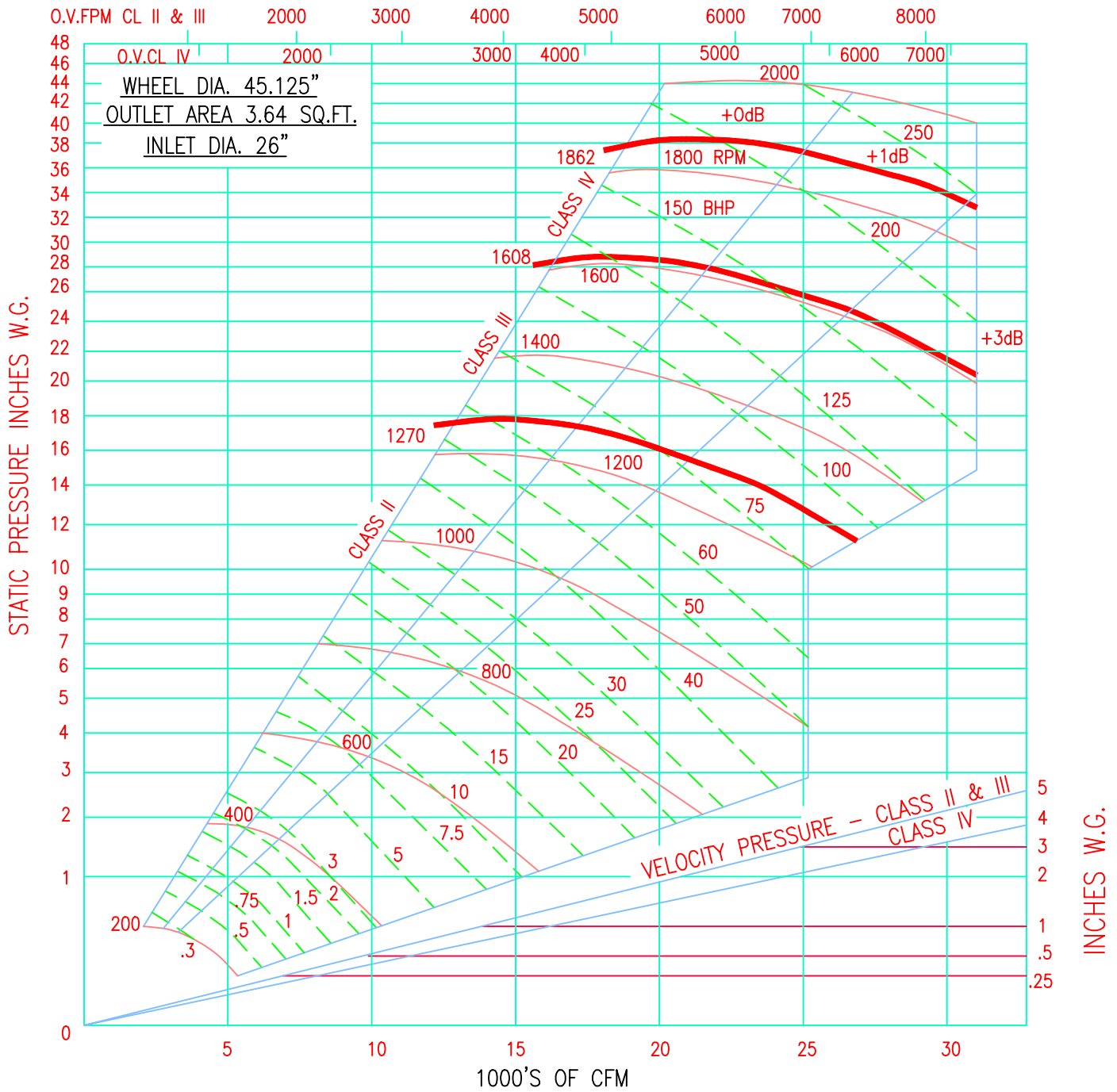

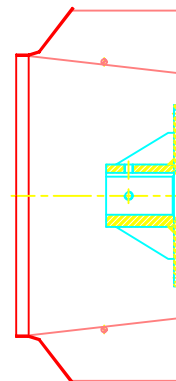
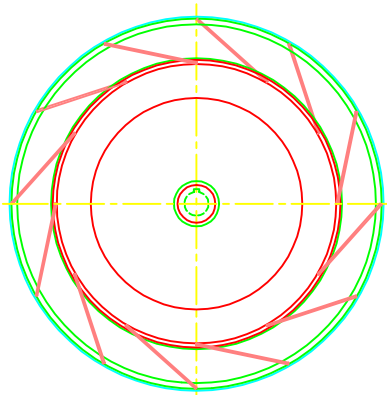
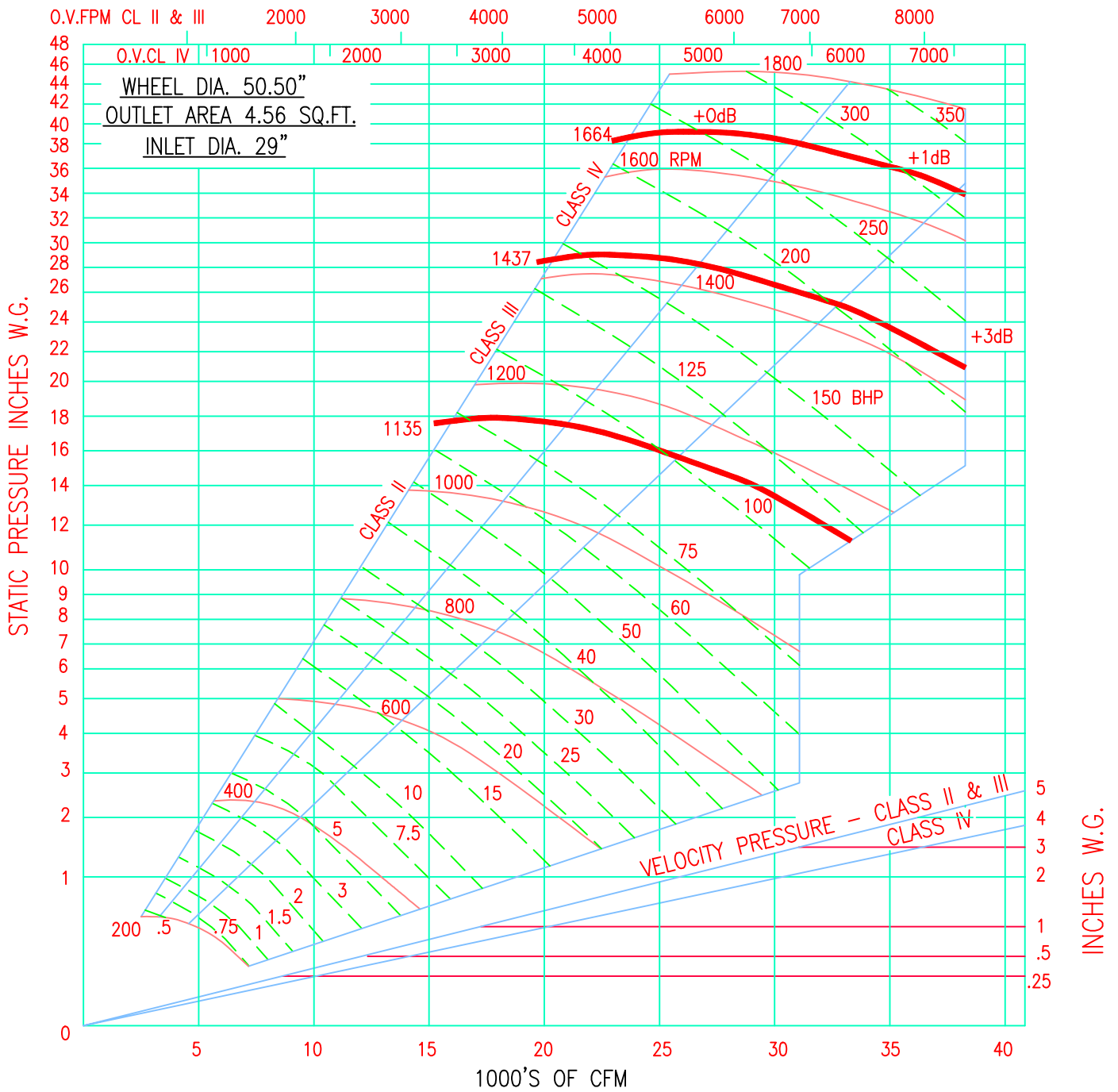

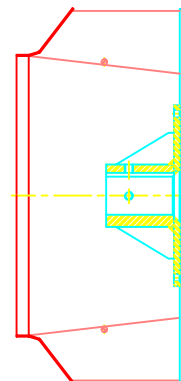
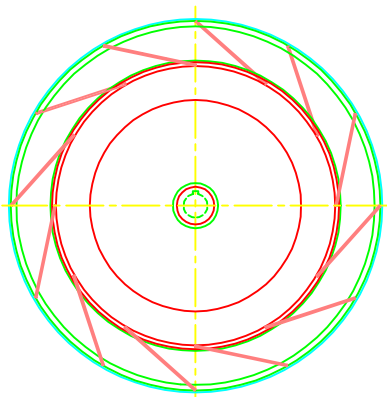
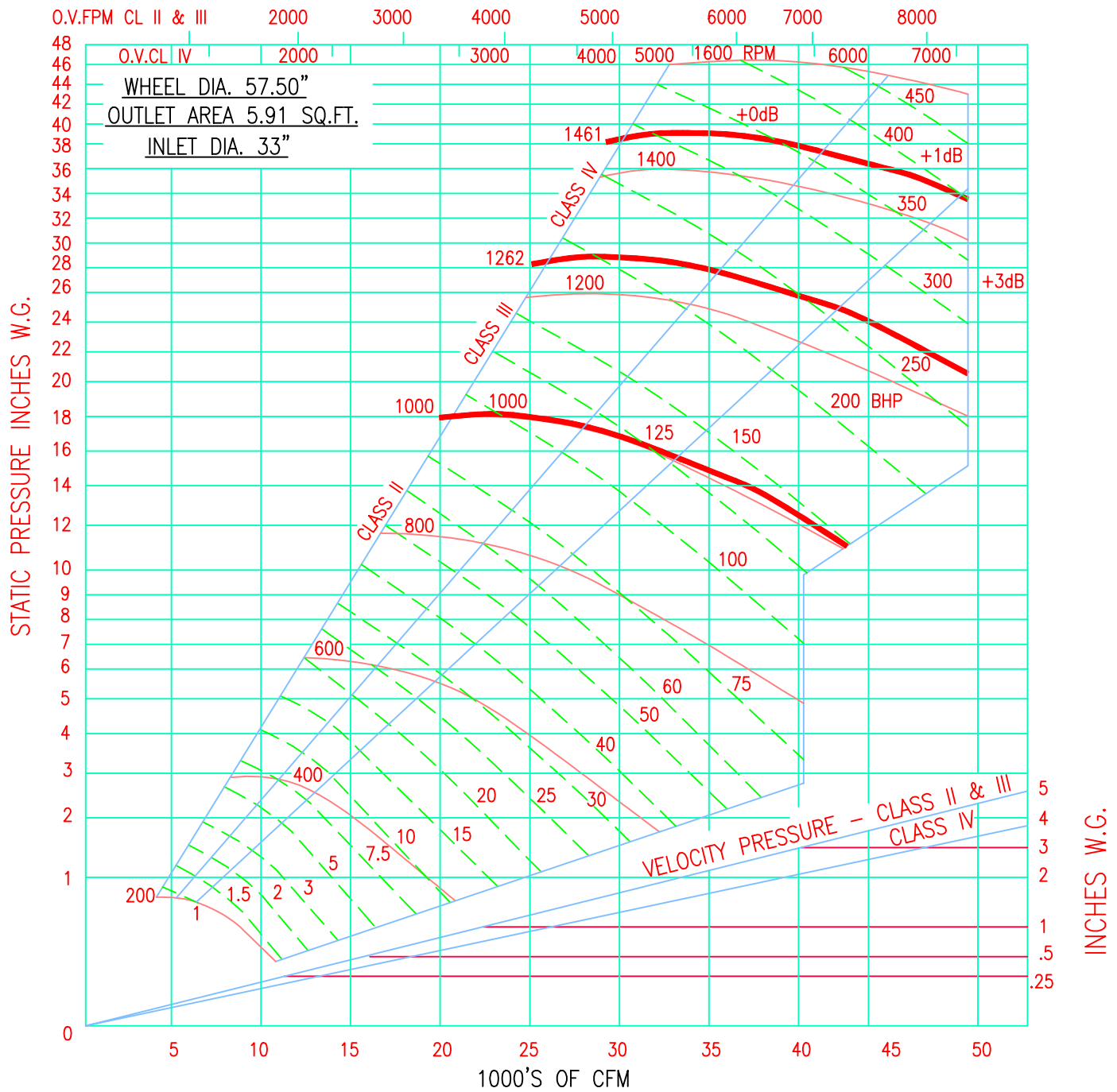

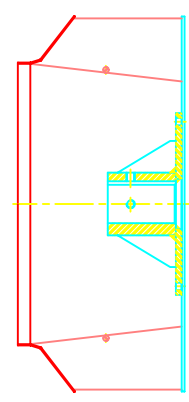
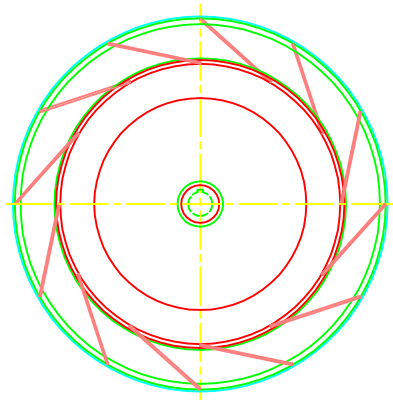
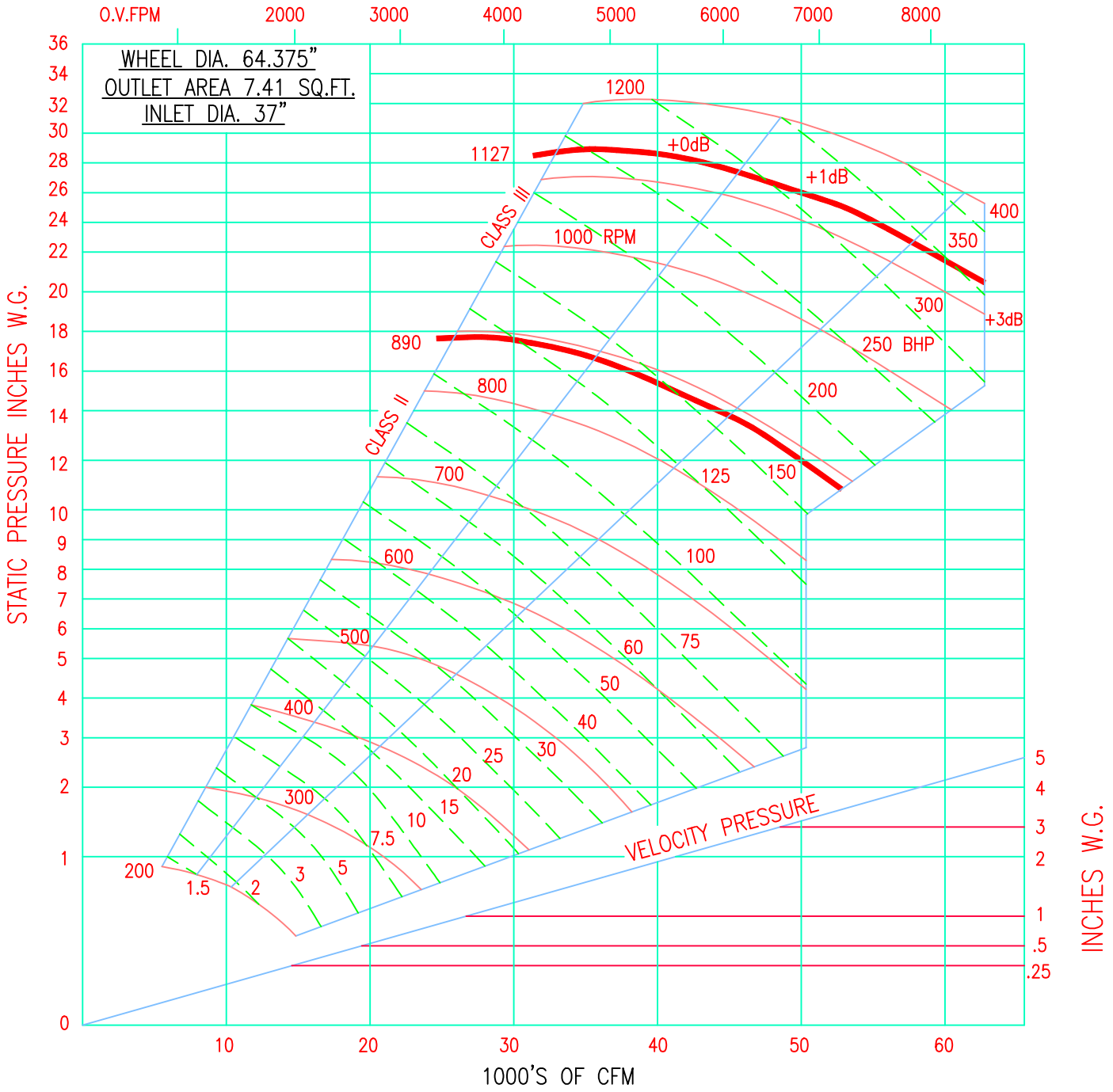

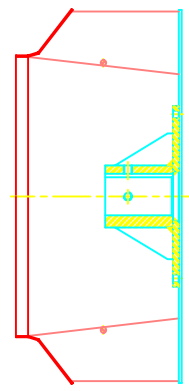
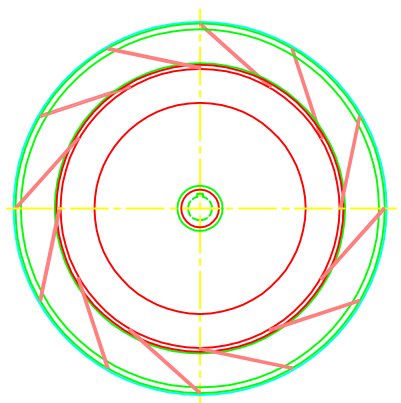
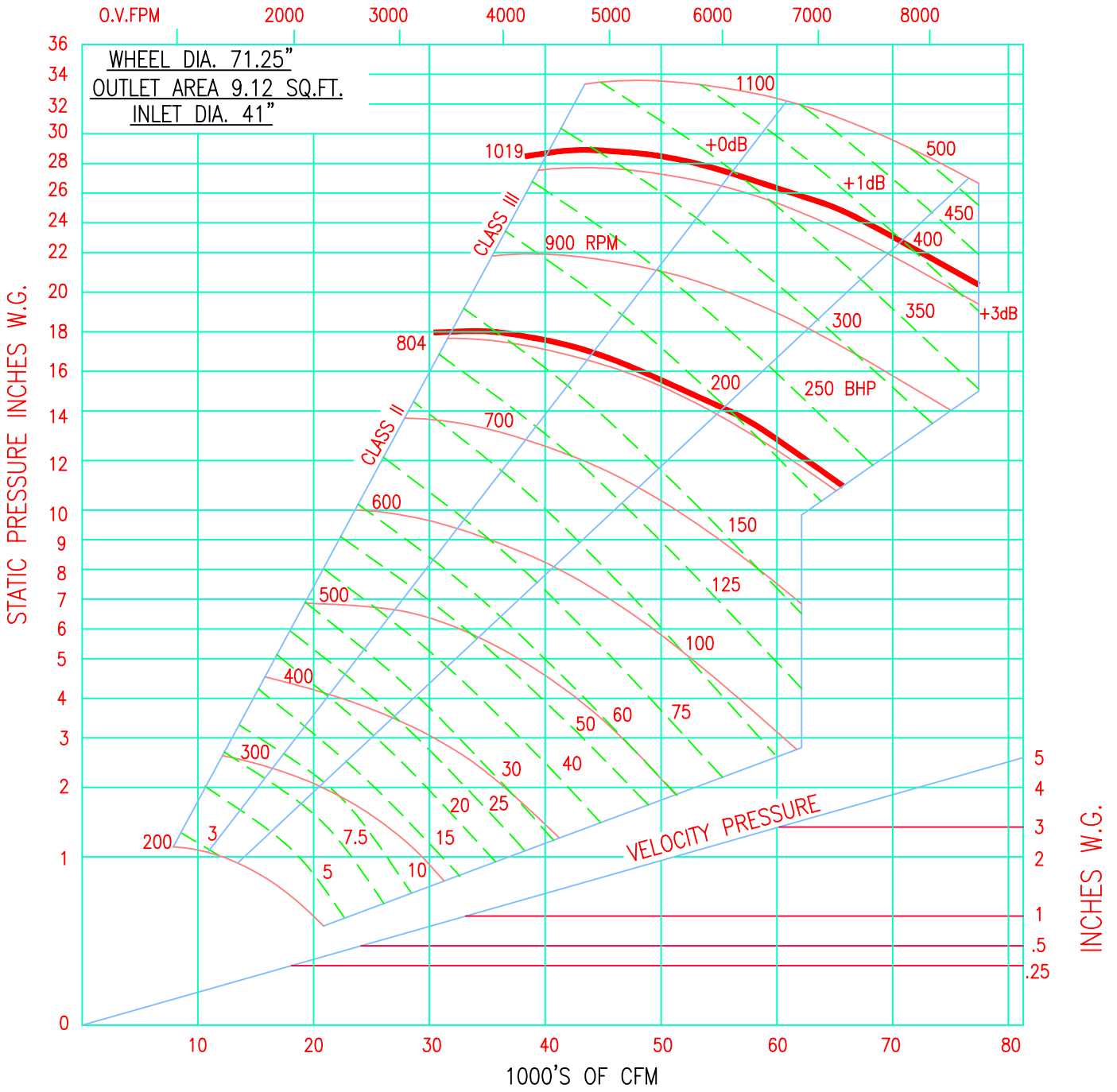

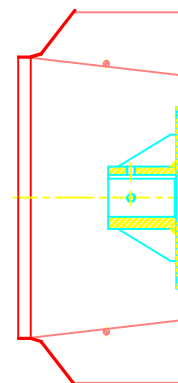
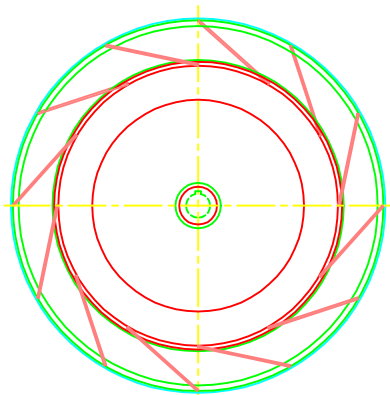
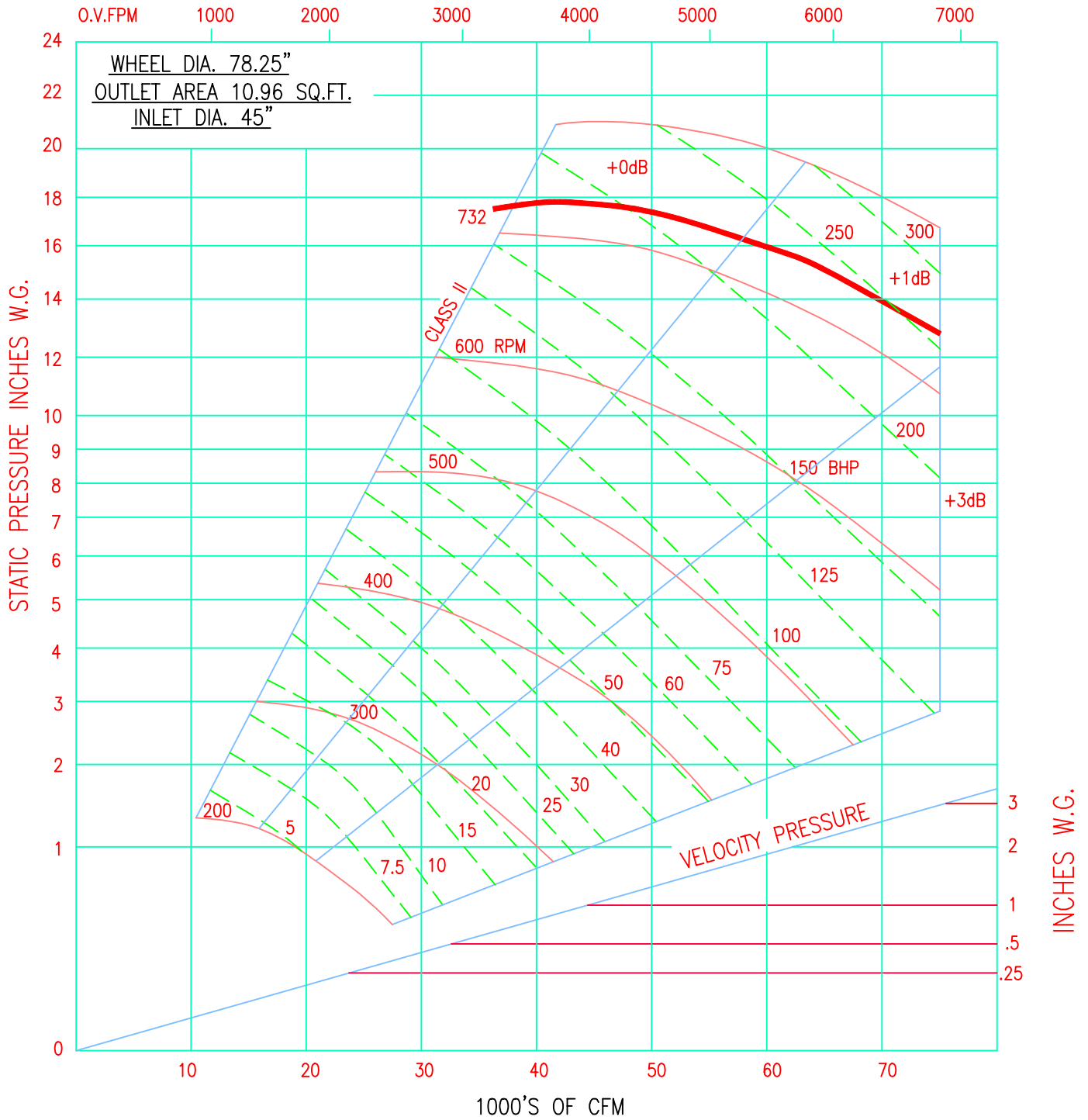

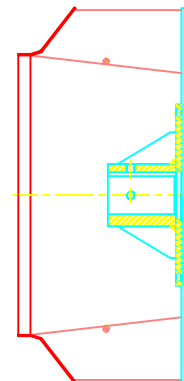
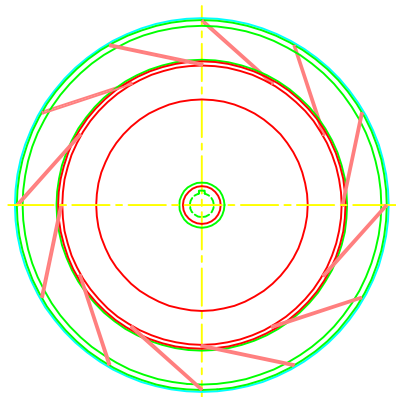
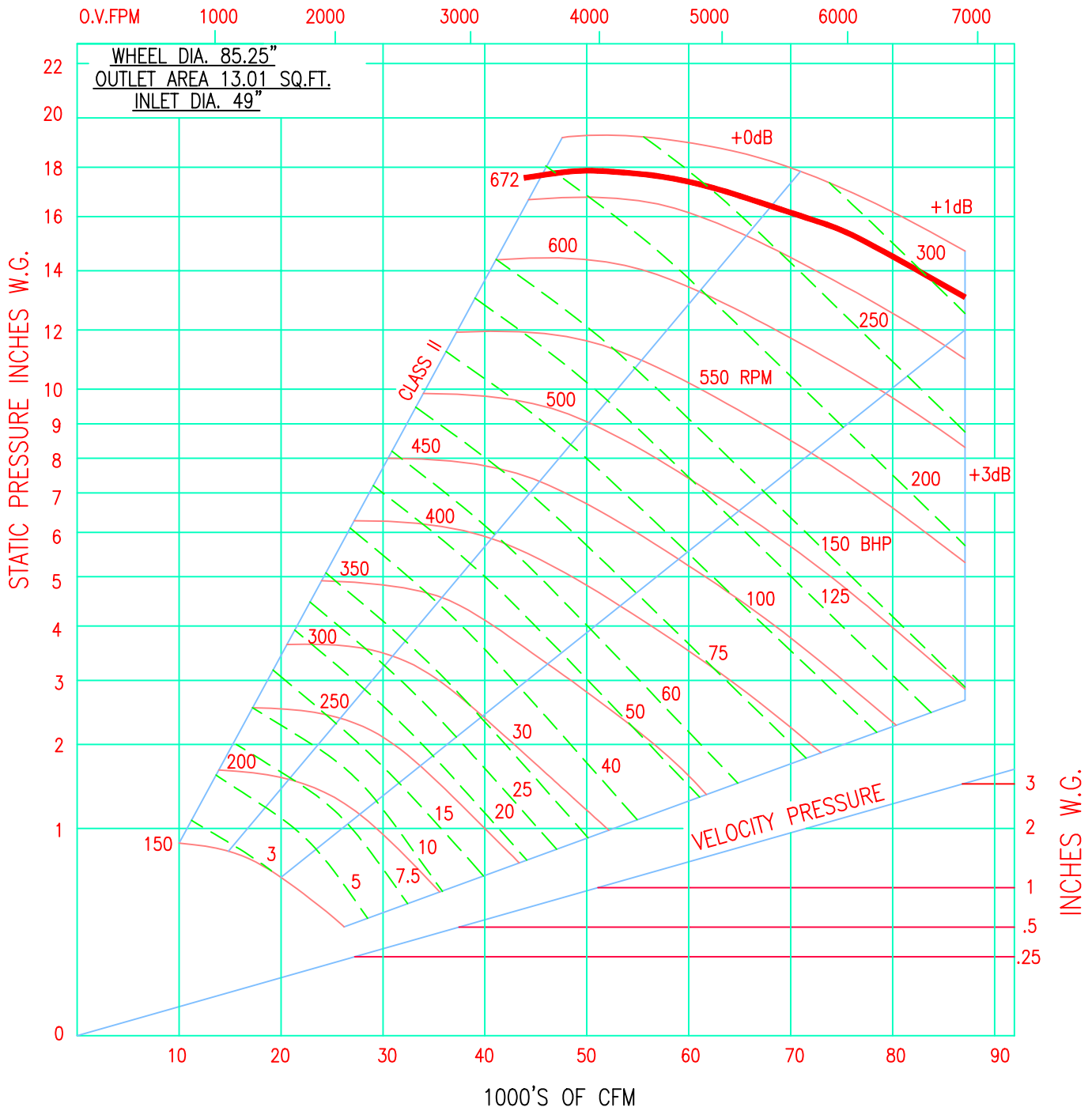

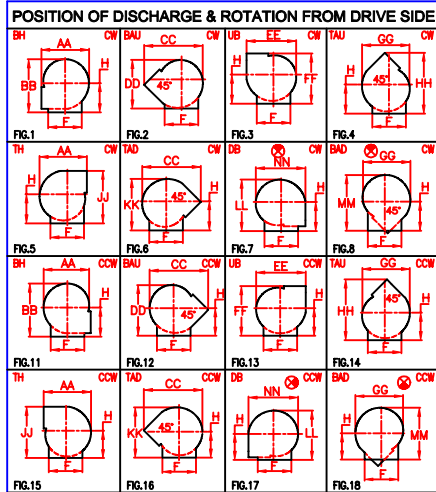

ARRANGEMENT 9 ILLUSTRATED (9L SHOWN, 9R OPP. HAND).
ARRANGEMENT 1 SAME AS ILLUSTRATED BUT WITHOUT MOTOR

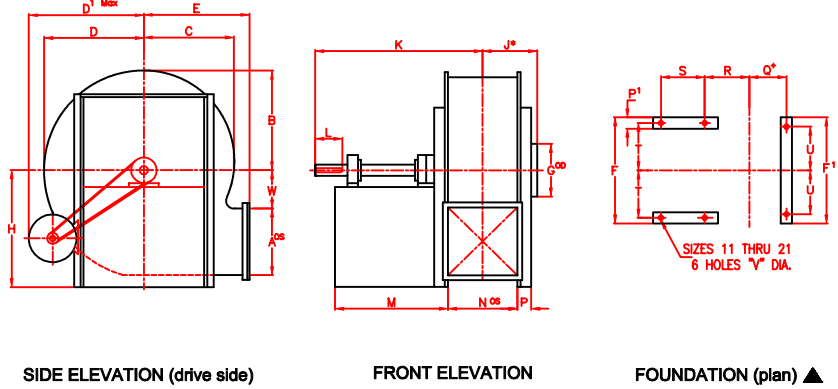

DIMENSIONS - INCHES (DOUBLE LETTER DIMENSIONS ARE FOR OVERALL REFERENCE ONLY)

FAN SIZE	WHEEL DIA.	SHAFT DIA.		KEYWAY SIZE		A	B	C	D	D ¹	E	F	F ¹	G	H	K	L	M	N	P	P ¹	Q+
		CL II	CL III	CL II	CL III																	
11	19 1/8	1 7/16	1 11/16	3/8x3/16	3/8x3/16	10 5/8	14 7/16	13 1/6	15 13/16	18 1/2	15	16 7/8	13 1/2	11	20	26 5/16	4	17 3/8	9 5/16	2	1 5/8	5 25/32
13	22 5/8	1 7/16	1 11/16	3/8x3/16	3/8x3/16	12 5/8	17 1/16	15 7/16	18 11/16	20 1/2	17 7/16	15 7/8	17	13	23	32 7/16	4 1/2	22 1/8	11 1/16	2	2 1/8	6 23/32
15	26 1/8	1 15/16	2 3/16	1/2x1/4	1/2x1/4	14 1/2	19 9/16	17 11/16	21 7/16	23 1/4	19 7/8	18 1/8	18 1/2	15	26	35 3/8	5 1/4	23 1/2	12 3/4	2	2 1/8	7 1/2
17	29 5/8	1 15/16	2 3/16	1/2x1/4	1/2x1/4	16 7/16	22 1/16	19 15/16	24 3/16	27	22 1/4	20 1/8	21	17	29	38 9/16	5 1/4	25 7/8	14 3/8	2	2 1/8	8 5/16
19	33	2 3/16	2 7/16	1/2x1/4	5/8x5/16	18 1/4	24 1/2	22 1/8	26 7/8	28 1/8	24 11/16	22 1/4	23	19	32	41 3/8	5 3/4	27 3/8	16	2	2 1/8	9 1/8
21	36 1/2	2 3/16	2 7/16	1/2x1/4	5/8x5/16	20 3/16	27 1/16	24 7/16	29 11/16	29 1/8	27 1/8	24 1/4	25	21	35	42 1/4	5 3/4	27 3/8	17 11/16	2	2 1/8	9 31/32

+ FOR TYPE "C" SPARK RESISTANT CONSTRUCTION 200 F AND ABOVE, ADD 3/8" TO DIMENSIONS SHOWN.

FAN SIZE	R	S	T	U	V	W	XO WHEEL	XB WHEEL	AA	BB	CC	DD	EE	FF	GG	HH	JJ	KK	LL	MM	NN
11	8 3/32	10 1/2	7 13/16	4 1/2	9/16		8 3/32	7 23/32	30 13/16	34 7/16	38 5/8	33 3/4	32 5/8	35	30 1/4	43 1/2	38 3/16	36 1/2	35 13/16	35 1/8	31 1/8
13	9 1/32	15 1/8	7 1/16	7 1/16	9/16	7 3/16	9 7/32	8 3/4	36 1/8	40 1/16	45 1/4	39 1/4	38 3/8	40 7/16	35 3/4	50 7/16	44 5/16	42 1/2	41 11/16	40 7/8	36 7/8
15	9 7/8	16 1/2	8 3/16	8 3/16	9/16	8 5/16	10 1/8	9 19/32	41 5/16	45 9/16	51 3/4	44 5/8	43 7/8	45 7/8	41	57 1/4	50 5/16	48 3/8	47 7/16	46 1/2	42 3/8
17	10 11/16	18 7/8	9 3/16	9 3/16	9/16	9 3/8	11 1/16	10 1/2	46 7/16	51 1/16	58 3/16	50	49 3/8	51 1/4	46 1/4	64 1/16	56 6/16	54 1/4	53 3/16	52 1/8	47 3/8
19	11 1/2	20 3/8	10 1/4	10 1/4	9/16	10 1/2	12	11 3/8	51 9/16	56 1/2	64 9/16	55 5/16	54 3/4	56 11/16	51 3/8	70 7/8	62 1/4	60 1/16	58 7/8	57 11/16	53 1/4
21	12 11/32	20 3/8	11 1/4	11 1/4	9/16	11 5/8	14 1/32	13 3/8	56 13/16	62 1/16	71 1/8	60 3/4	60 3/8	62 1/8	56 3/4	77 3/4	68 5/16	66	64 11/16	63 3/8	58 7/8

FAN SIZE	T-FRAMES		U-FRAMES		FRAME 56		FRAME 143-145		FRAME 182-184		FRAME 213-215		FRAME 254-256		FRAME 284-286		FRAME 324-326		FRAME 364-365		
	ODP&TEFC	ODP	TEFC	MIN.	MAX.	MIN.	MAX.	MIN.	MAX.	MIN.	MAX.	MIN.	MAX.	MIN.	MAX.	MIN.	MAX.	MIN.	MAX.	MIN.	MAX.
11	215T	215	215	14.7	16.8	14.7	16.8	15.8	17.8	16.5	18.6										
13	256T	286U	284U	15	17.2	15	17.2	16	18.1	16.5	19	17.3	20	17.8	20.8						
15	284T	286U	286U	17	19.2	17	19.2	18	20.1	18.5	21	19.3	22	19.8	22.8						
17	324T	364U	364U	18.7	21	18.7	21	19.6	21.8	20.2	22.3	21	23.7	21.4	24.4	22.4	25.7	23	26.7		
19	326T	365U	365U	20.6	22.9	20.6	22.9	21.5	23.7	22	24.6	22.9	25.6	23.3	26.3	24.1	27.6	24.8	28.6		
21	326T	365U	365U	22.8	25.1	22.8	25.1	23.6	25.9	24.2	26.7	24.9	27.8	25.3	28.4	26.5	29.9	26.8	30.7		

ITEM NO	IDENTIFICATION	ARRGT	NO. REQ'D	FAN SIZE	FIG. NO.	WHEEL TYPE	CL.	PERFORMANCE					MOTOR DATA										
								CFM	O.V.	SP	R.P.M.	TEMP.	BHP	ELEV.	H.P.	R.P.M.	CURRENT	FRAME	TYPE				

ITEM NO	MOTOR BASE	DRIVE DATA				MOTOR POS.	VIBRATION BASE TYPE	PADS TYPE	SPECIAL FEATURES
		MOTOR PULLEY	FAN PULLEY	BELTS	CENTER				

OPTIONAL ACCESSORIES

- A=FLANGED INLET
- PUNCHING UNPUNCHED
- B=CLEANOUT DOOR-BOLTED
- C=CLEANOUT DOOR-QUICK CLAMP
- D=CLEANOUT DOOR-PLUG TYPE
- E=DRAIN OPENING
- F=SPECIAL FINISH-SEE NOTES
- G=SHAFT SEAL
- H=SPARK RESIST.CONST.(SEE NOTES)
- J=OUTLET DAMPER
- K=HEAVY DUTY HOUSING
- L=COOLING WHEEL
- M=INLET SCREEN
- N=HEAVY DUTY L.S. WHEEL
- P=BELT GUARD
- Q=SHAFT/BEARING GUARD
- R=EXT. GREASE FITTING COPPER
- S=MOUNT MOTOR & DRIVES
- T=INLET BOX
- U=INLET BOX DAMPER
- V=PUNCHED FLANGED OUTLET
- DB & BAD ONLY
- W=SLIP FIT INLET
- X=DRILL AND TAP SHAFT C/W HUB CAP

NOTES

- ⊗ Flanged outlet is not std. on DB & BAD units. When flanged outlet (punched) is required on DB (Fig.7&17) or BAD (Fig.8&18) units.
- ▲ When vibration or unitary base is furnished disregard foundation plan shown above and refer to vibration or unitary base Dwg. Refer to order acknowledgment for shipping details.

CUSTOMER _____

JOB NAME _____

LOCATION _____

P.O.# _____



SERIES 9000
ARRANGEMENT 1 & 9 SISW CLASSES II & III
FIXED DISCHARGE - SIZES 11 TO 21
SHELDONS ENGINEERING
www.sheldonsengineering.com
sales@sheldonsengineering.com

FURNISHED FOR SALES PURPOSE DIMENSIONS NOT CERTIFIED	DATE	SUBMITTED BY	SALES OFFICE
DRAWING CERTIFIED BY S.E. FURNISHED FOR APPROVAL-NOT RELEASED FOR PRODUCTION	DATE	ENGINEER	SO#
DRAWING CERTIFIED BY S.E. APPROVAL-NOT REQUIRED-RELEASED FOR PRODUCTION	DATE	ENGINEER	DWG#

* WHEEL TYPES: XO = Long Shavings, XB = Air/Material

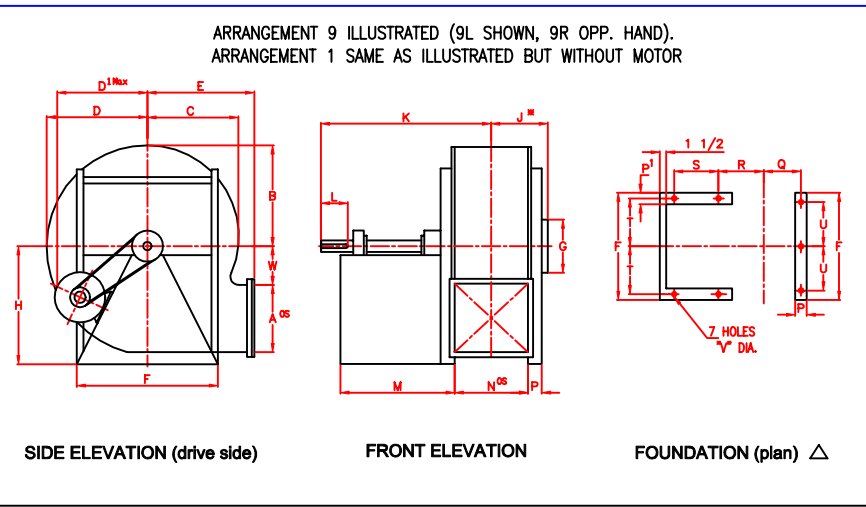
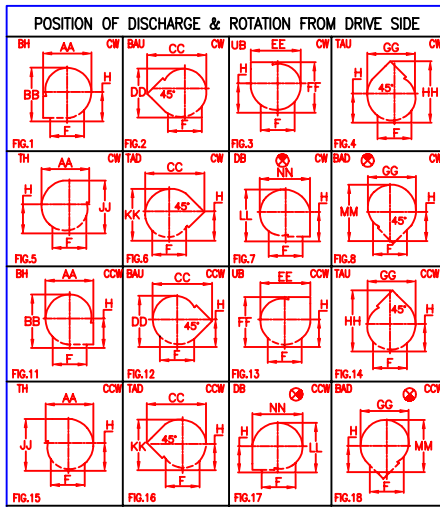

DIMENSIONS - INCHES (DOUBLE LETTER DIMENSIONS ARE FOR OVERALL REFERENCE ONLY)

FAN SIZE	WHEEL DIA.	SHAFT DIA.			KEYWAY SIZE			A	B	C	D	D'	E	F	G	H	K	L	M	N	P	P'
		CL I	CL II	CL III	CL I	CL II	CL III															
23	40	2 3/16	2 7/16	2 11/16	1/2x1/4	5/8x5/16	5/8x5	22 1/8	29 3/16	26 5/16	32 1/16	34 5/16	29 5/8	37	23	39	50 3/16	7	34 1/2	19 5/16	2 1/2	2 1/2
26	45 1/8	2 3/16	2 11/16	2 15/16	1/2x1/4	5/8x5/16	3/4x3/8	24 15/16	32 15/16	29 11/16	36 3/16	37 3/4	33 3/16	42 1/2	26	44	52 15/16	7	36 1/16	22 3/16	2 1/2	3
29	50 1/2	2 7/16	2 11/16	3 3/16	5/8x5/16	5/8x5/16	3/4x3/8	27 3/4	36 13/16	33 3/16	40 7/16	41 9/16	37	46 1/4	29	48	58 3/4	8 1/2	39 1/16	24 17/32	2 1/2	3
33	57 1/2	2 7/16	2 15/16	3 3/16	5/8x5/16	3/4x3/8	3/4x3/8	31 3/4	41 15/16	37 3/4	46	43 1/8	41 15/16	51 3/4	33	54	60 7/8	8 1/2	39 9/16	27 11/16	2 1/2	4
37	64 3/8	2 11/16	3 3/16	3 7/16	5/8x5/16	3/4x3/8	7/8x7/16	35 1/2	46 7/8	42 1/2	51 1/2	45 13/16	46 13/16	57 1/2	37	60	62 9/16	8 1/2	39 9/16	31	3	4
FAN SIZE	Q	R	S	T	U	V	W	XO WHEEL	XB WHEEL	AA	BB	CC	DD	EE	FF	GG	HH	JJ	KK	LL	MM	
								J	J	AA	BB	CC	DD	EE	FF	GG	HH	JJ	KK	LL	MM	
23	10 7/8	13 5/8	25	17 3/8	15 1/2	7/8	12 3/4	15 21/32	15 1/8	61 11/16	68 3/16	76 3/16	66 3/4	64 1/2	68 5/8	62 3/8	84 5/8	73 7/8	72 1/2	71 1/16	69 5/8	
26	12 5/16	16 1/16	26 1/2	20	18	7/8	14 7/16	17 7/32	16 5/8	69 3/8	76 15/16	85 13/16	75 1/4	72 5/16	77 3/16	69 1/8	95 5/16	83 3/8	81 7/8	80 3/16	78 1/2	
29	13 1/2	17 1/4	29 1/2	21 7/8	19 3/4	7/8	16 5/16	18 7/32	17 9/16	77 7/16	84 13/16	96	83	80 15/16	85	77 1/4	105 5/16	92 1/16	90 3/8	88 1/2	86 5/8	
33	15 1/8	18 13/16	30	24 3/8	21 7/8	1	18 7/16	19 29/32	19 5/32	87 15/16	95 15/16	109 1/4	94	92 1/8	95 15/16	88	119 1/8	104 3/16	102 1/8	100	98 1/8	
37	17	20 1/2	30	27 1/4	24 3/4	1	20 5/8	23 3/16	22 11/32	98 5/16	106 7/8	122	104 9/16	103	106 13/16	98 3/8	132 3/4	116 1/8	113 13/16	111 1/2	109 3/16	

FAN SIZE	MAXIMUM MOTOR				ARRANGEMENT 9 DRIVE CENTERS															
	T-FRAMES		U-FRAMES		FRAME 182-184		FRAME 213-215		FRAME 254-256		FRAME 284-286		FRAME 324-326		FRAME 364-365		FRAME 404-405		FRAME 444-445	
	ODP&TEFC	ODP	TEFC	MIN.	MAX.	MIN.	MAX.	MIN.	MAX.	MIN.	MAX.	MIN.	MAX.	MIN.	MAX.	MIN.	MAX.	MIN.	MAX.	
23	365T	365	365	22.3	25	24.6	27.6	26.3	29.8	27.1	31	29.2	33.6	29.5	34.5					
26	405T	405	405	21.8	24.5	24.1	27.1	26	29.3	26.7	30.5	28.8	33.3	30.1	35.1	30.6	36.3			
29	444T	445	444			24.7	27.7	26.5	30	27.3	31.1	29.5	33.8	30.7	35.7	32.5	38.3	33	39	
33	444T	445	444			27.7	31	28.2	31.7	28.3	32.2	29	33.3	31.5	36.5	34.5	40.5	37	43.5	
37	444T	445	444					30.2	33.6	32	36	35	39.6	37.5	42.8	40.7	46.8	43.2	49.7	

ITEM NO	IDENTIFICATION	ARRG'T	NO. REQ'D	FAN SIZE	FIG. NO.	WHEEL TYPE	CL.	PERFORMANCE						MOTOR DATA								
								CFM	O.V.	SP	R.P.M.	TEMP.	BHP	ELEV.	H.P.	R.P.M.	CURRENT	FRAME	TYPE			

ITEM NO	MOTOR BASE	DRIVE DATA				MOTOR POS.	VIBRATION BASE TYPE	PADS TYPE	SPECIAL FEATURES
		MOTOR PULLEY	FAN PULLEY	BELTS	CENTER				

NOTES
 Δ When vibration or unitary base is furnished disregard foundation plan shown above and refer to vibration or unitary base Dwg.
 Refer to order acknowledgment for shipping details.

OPTIONAL ACCESSORIES

A=FLANGED INLET PUNCHED
 B=CLEANOUT DOOR-BOLTED
 C=CLEANOUT DOOR-QUICK CLAMP
 D=CLEANOUT DOOR-PLUG TYPE
 E=DRAIN OPENING
 F=SPECIAL FINISH-SEE NOTES
 G=SHAFT SEAL
 H=SPARK RESIST.CONST.(SEE NOTES)
 J=OUTLET DAMPER
 K=SHAFT AND BRG. GUARD
 L=HEAVY DUTY HOUSING

M=SHAFT COOLER AND GUARD
 N=INLET SCREEN
 P=HEAVY DUTY L.S. WHEEL
 Q=HORIZONTAL SPLIT HOUSING
 R=BELT GUARD
 S=EXT. GREASE FITTINGS
 T=MOUNT MOTOR & DRIVES
 U=INLET BOX
 V=INLET BOX DAMPER
 W=SLIP FIT INLET

SERIES 9000
ARRANGEMENT 1 & 9 SISW CLASSES I, II & III
FIXED DISCHARGE - SIZES 23 TO 37

SHELDONS ENGINEERING
 www.sheldonsengineering.com
 sales@sheldonsengineering.com

FURNISHED FOR SALES PURPOSE DIMENSIONS NOT CERTIFIED	DATE	SUBMITTED BY	SALES OFFICE
DRAWING CERTIFIED BY S.E. APPROVAL - NOT RELEASED FOR PRODUCTION	DATE	ENGINEER	SO#
DRAWING CERTIFIED BY S.E. APPROVAL - NOT REQUIRED - RELEASED FOR PRODUCTION	DATE	ENGINEER	DWG#

* WHEEL TYPES: XO = Long Shavings, XB = Air/Material

POSITION OF DISCHARGE & ROTATION FROM DRIVE SIDE

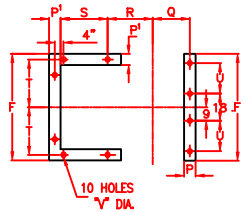
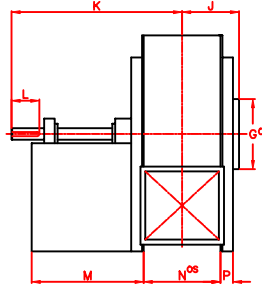
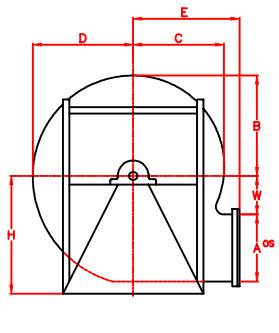
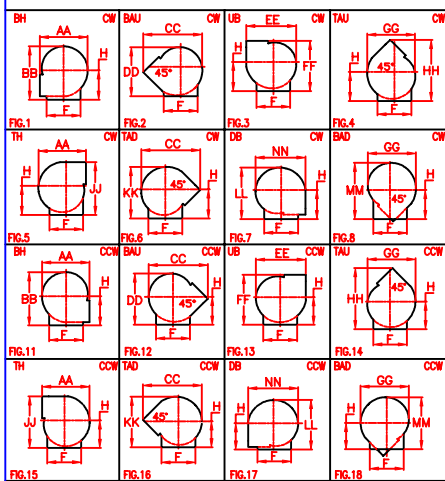

SIDE ELEVATION (drive side)

FRONT ELEVATION

FOUNDATION (plan)

DIMENSIONS - INCHES (DOUBLE LETTER DIMENSIONS ARE FOR OVERALL REFERENCE ONLY)

FAN SIZE	WHEEL DIA.	SHAFT DIA.		KEYWAY SIZE		A	B	C	D	E	F	G	H						K	L	M	N
		CL II	CL III	CL II	CL III								FIG. 1 & 11	FIG. 2 & 12	FIG. 3 & 13	FIG. 4 & 14	FIG. 5 & 15	FIG. 6 & 16				
41	71 1/4	3 7/16	3 11/16	7/8x7/16	7/8x7/16	39 1/4	51 7/8	46 3/4	57	52 3/32	74	41	67	64	61 1/2	59	56 1/2	56 1/2	66	8 1/2	44 5/16	34 1/2
45	78 1/4	3 11/16	3 15/16	7/8x7/16	1"x1/2	43 1/16	56 15/16	51 5/16	62 9/16	57	74	45 7/2	72 1/2	67	64	61 1/2	59	67 5/8	8 1/2	44 5/16	37 3/4	

FAN SIZE	P	P ¹	Q	R	S	T	T ¹	U	V	W	XO WHEEL*	XB WHEEL	AA	BB	CC	DD	EE	FF	GG	HH	JJ	KK
											J	J										
41	4	5	19 3/4	23 1/4	32 5/16	35	20	21	15/16	22 7/8	24 1/2	23 1/4	114	119	142	114	122	115	117	142	122	116
45	4	5	21 3/8	24 7/8	32 5/16	35	20	21	15/16	25 1/8	25 1/32	23 1/4	125	130	155	127	134	125	128	155	133	125

ITEM NO.	IDENTIFICATION	ARRG'T	NO. REQ'D	FAN SIZE	FIG. NO.	WHEEL TYPE	CL.	PERFORMANCE						MOTOR DATA									
								CFM	O.V.	SP	R.P.M.	TEMP.	BHP	ELEV.	H.P.	R.P.M.	CURRENT	FRAME	TYPE				

ITEM NO.	MOTOR BASE	DRIVE DATA			MOTOR POS.	VIBRATION BASE TYPE	PADS TYPE	SPECIAL FEATURES
		MOTOR PULLEY	FAN PULLEY	BELTS				

NOTES

SPECIAL FEATURES

- A=FLANGED INLET
- B=FLANGED OUTLET
- C=CLEANOUT DOOR-BOLTED
- D=CLEANOUT DOOR-QUICK CLAMP
- E=CLEANOUT DOOR-PLUG TYPE
- F=DRAIN OPENING
- G=SPECIAL FINISH-SEE NOTES
- H=SHAFT SEAL
- J=SPARK RESIST.CONST.(SEE NOTES)
- K=OUTLET DAMPER -ST'D
- L=OUTLET DAMPER-PARAFLO
- M=HEAVY DUTY HOUSING
- N=STAINLESS STEEL (SEE NOTES)
- P=COOLING WHEEL
- Q=INLET SCREEN
- R=HEAVY DUTY L.S. WHEEL
- S=INSULATION STUDS
- T=SLIP FIT INLET

CUSTOMER _____

JOB NAME _____ P.O.# _____

LOCATION _____

SERIES 9000
ARRANGEMENT 1 & 9 SISW CLASSES II & III
FIXED DISCHARGE - SIZES 41 & 45
SHELDONS ENGINEERING
 www.sheldonsengineering.com
 sales@sheldonsengineering.com

FURNISHED FOR SALES PURPOSE DIMENSIONS NOT CERTIFIED	DATE	SUBMITTED BY	SALES OFFICE
DRAWING CERTIFIED BY S.E. APPROVAL-NOT RELEASED FOR PRODUCTION	DATE	ENGINEER	SO#
DRAWING CERTIFIED BY S.E. APPROVAL-NOT REQUIRED-RELEASED FOR PRODUCTION	DATE	ENGINEER	DWG#

* WHEEL TYPES: XO = Long Shavings, XB = Air/Material

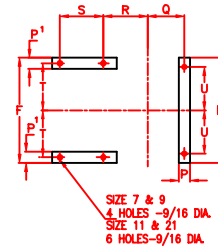
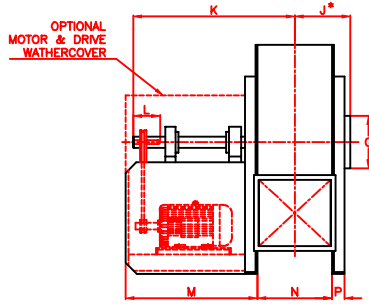
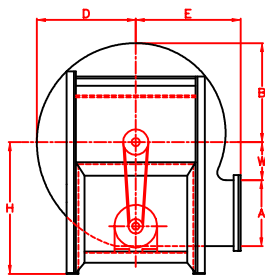

DIMENSIONS - INCHES (DOUBLE LETTER DIMENSIONS ARE FOR OVERALL REFERENCE ONLY)

FAN SIZE	WHEEL TYPE		SHAFT DIA.		KEYWAY SIZE		A	B	D	E	F	F ¹	G	H	K	L	M
	XO	XB	CL I	CL II	CL I	CL II											
7	12 1/4	12 1/4	15/16	1 3/16	1/4x1/8	1/4x1/8	6 13/16	8 7/8	9 3/4	9 5/16	14 5/8		7	17	20 9/16	3	18 1/2
11	19 1/8	19 1/8	1 3/16	1 7/16	1/4x1/8	3/8x3/16	10 5/8	13 15/16	15 5/16	14 1/2	17 3/8	13 1/2	11	20	26 5/16	4	22 3/4
13	22 5/8	22 5/8	1 3/16	1 7/16	1/4x1/8	3/8x3/16	12 5/8	16 9/16	18 3/16	16 15/16	21	17	13	23	32 7/16	4 1/2	28
15	26 1/8	26 1/8	1 7/16	1 15/16	3/8x3/16	1/2x1/4	14 1/2	19 1/16	20 15/16	19 3/8	18 3/8	18 1/2	15	26	35 3/8	5 1/4	30
17	29 5/8	29 5/8	1 7/16	1 15/16	3/8x3/16	1/2x1/4	16 7/16	21 9/16	23 11/16	21 3/4	21	21	17	29	38 9/16	5 1/2	32 1/2
19	33	33	1 11/16	2 3/16	3/8x3/16	1/2x1/4	18 1/4	24	26 3/8	24 3/16	22 3/8	23	19	32	41 3/8	5 3/4	34 3/8
21	36 1/2	36 1/2	1 15/16	2 3/16	1/2x1/4	1/2x1/4	20 3/16	26 9/16	29 3/16	26 5/8	26 3/8	25	21	35	42 1/4	5 3/4	34 3/8

FAN SIZE	N	P	P ¹	Q	R	S	T	U	W	MAX. FRAME
7	6 5/16		1 5/8		6 23/32	11 5/8	6 9/16		3 13/16	145T
11	9 5/16	1 1/2	1 5/8	5 17/32	8 3/32	15 7/8	7 15/16	4 1/2	6 1/16	215T
13	11 1/16	2	1 5/8	6 21/32	9 1/32	21 1/16	10 1/8	7 1/16	7 3/16	215T
15	12 3/4	2	2 1/8	7 1/2	9 7/8	23 1/16	8 7/16	8 3/16	8 5/16	215T
17	14 3/8	2	2 1/8	8 5/16	10 11/16	25 1/2	9 5/8	9 3/16	9 3/8	215T
19	6	2	2 1/8	9 1/8	11 1/2	27 3/8	10 7/16	10 1/4	10 1/2	236T
21	17 11/16	2	2 1/8	9 31/32	12 11/32	27 3/4	12 7/16	11 1/4	11 5/8	236T

OPTIONAL ACCESSORIES

- A=FLANGED INLET
- B=FLANGED OUTLET
- C=CLEANOUT DOOR-BOLTED
- D=CLEANOUT DOOR-QUICK CLAMP
- E=CLEANOUT DOOR-PLUG TYPE
- F=DRAIN OPENING
- G=SPECIAL FINISH-SEE NOTES
- H=SHAFT SEAL
- J=OUTLET DAMPER
- K=HEAVY DUTY HOUSING
- L=COOLING WHEEL
- M=INLET SCREEN
- N=HEAVY DUTY XO WHEEL
- P=BELT GUARD
- Q=SLIP FIT INLET
- R=MOTOR AND DRIVE WEATHERCOVER
- S=XB WHEEL

POSITION OF DISCHARGE & ROTATION FROM DRIVE SIDE

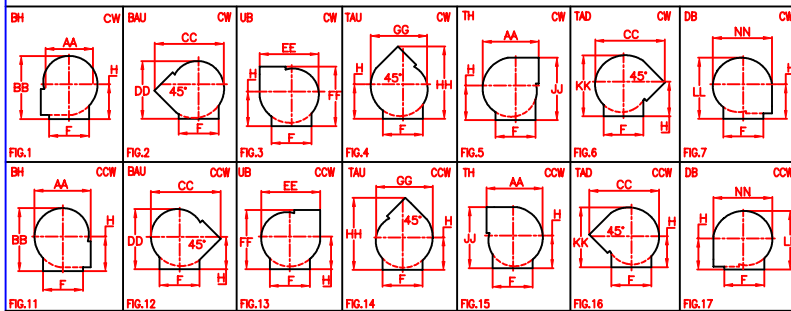

ITEM NO.	IDENTIFICATION	NO. REQD.	WHEEL DATA		FIG. NO.	PERFORMANCE											
			SIZE	TYPE		CFM	O.V.	SP	R.P.M.	BHP	TEMP.	ELEV.					

ITEM NO.	MOTOR DATA				DRIVE DATA					
	H.P.	R.P.M.	CURRENT	FRAME	TYPE	MOTOR PULLEY	FAN PULLEY	BELTS	CENTER	SPECIAL FEATURES

NOTES

CUSTOMER _____

JOB NAME _____ P.O.# _____

LOCATION _____



SERIES 9000
ARRANGEMENT 10 SISW CLASSES II & III
FIXED DISCHARGE

SHELDONS ENGINEERING
 www.sheldonsengineering.com
 sales@sheldonsengineering.com

FURNISHED FOR SALES PURPOSE DIMENSIONS NOT CERTIFIED	DATE	SUBMITTED BY	SALES OFFICE
DRAWING CERTIFIED BY S.E. FURNISHED FOR APPROVAL-NOT RELEASED FOR PRODUCTION	DATE	ENGINEER	SO#
DRAWING CERTIFIED BY S.E. APPROVAL-NOT REQUIRED-RELEASED FOR PRODUCTION	DATE	ENGINEER	DWG#

* WHEEL TYPES: XO = Long Shavings, XB = Air/Material

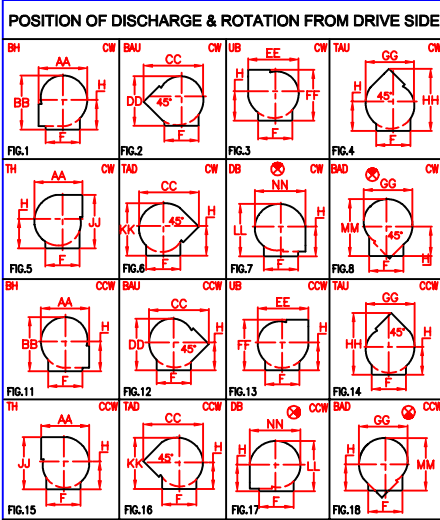

ARRANGEMENT 9 ILLUSTRATED (9L SHOWN, 9R OPP. HAND).
ARRANGEMENT 1 SAME AS ILLUSTRATED BUT WITHOUT MOTOR

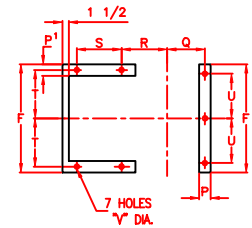
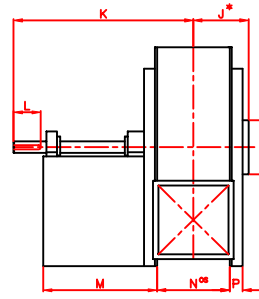
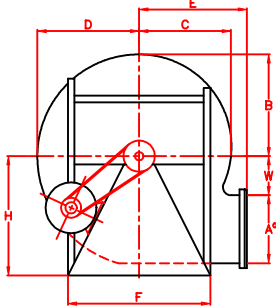

SIDE ELEVATION (drive side)

FRONT ELEVATION

FOUNDATION (plan) Δ

DIMENSIONS - INCHES (DOUBLE LETTER DIMENSIONS ARE FOR OVERALL REFERENCE ONLY)

FAN SIZE	WHEEL DIA.	SHAFT DIA.	KEYWAY SIZE	A	B	C	D	E	F	G	H	K	L	M	N	P	P ¹	Q
23	40	3 7/16	7/8 x 7/16	22 1/8	29 5/8	26 3/4	32 1/2	30 1/8	37	23	39	51 5/8	8 1/2	34 3/16	19 5/16	2 1/2	3	10 13/16
26	45 1/8	3 11/16	7/8 x 7/16	24 15/16	33 3/8	30 1/8	36 5/8	33 11/16	42 1/2	26	44	54 5/16	8	36 21/32	22 3/16	2 1/2	3	12 5/16
29	50 1/2	3 15/16	1 x 1/2	27 3/4	37 5/16	33 11/16	40 15/16	37 1/2	46 1/4	29	48	58	11 1/2	35 3/4	24 1/2	2 1/2	3	13 3/8
33	57 1/2	4 3/16	1 x 1/2	31 3/4	42 9/16	38 5/16	46 9/16	42 7/16	51 3/4	33	54	64 1/8	11 1/2	40 17/32	27 11/16	2 1/2	3	15 1/8

FAN SIZE	R	S	T	U	V	W	J	AA	BB	CC	DD	EE	FF	GG	HH	JJ	KK
23	14 19/32	28	17 1/4	15 1/2	7/8	12 3/4	15 21/32	62 5/8	68 5/8	78 7/16	67 3/16	66 1/2	69 1/8	62 1/8	86 3/8	75 7/8	72 15/16
26	16 3/8	30 1/8	20	18	7/8	14 7/16	17 7/32	70 5/16	77 3/8	88 1/16	75 3/4	74 3/4	77 11/16	70	97 1/16	85 3/8	82 1/4
29	15 1/4	31 1/2	22	19 3/4	7/8	16 5/16	18 7/32	78 7/16	85 5/16	98 1/4	83 1/2	83 3/8	85 1/2	78 1/4	107 1/16	94 1/16	90 3/4
33	19 1/8	34	24 5/8	21 7/8	1	18 7/16	19 29/32	89	96 9/16	111 7/16	94 3/8	94 3/4	96 7/16	89	120 15/16	106 3/16	102 5/8

FAN SIZE	MAXIMUM MOTOR			ARRANGEMENT 9 DRIVE CENTERS															
	T-FRAMES ODP&TEFC	U-FRAMES ODP	TEFC	FRAME 182-184		FRAME 213-215		FRAME 254-256		FRAME 284-286		FRAME 324-326		FRAME 364-365		FRAME 404-405		FRAME 444-445	
	MIN.	MAX.	MIN.	MAX.	MIN.	MAX.	MIN.	MAX.	MIN.	MAX.	MIN.	MAX.	MIN.	MAX.	MIN.	MAX.	MIN.	MAX.	
23	365T	365	365	22.3	25	24.6	27.6	26.3	29.8	27.1	31	28.9	32.9	29.5	34.5				
26	405T	405	405	22.6	24.3	24.8	26.9	26.7	28.8	27.4	29.9	29.6	32.7	30.8	34.5	31.0	35.4		
29	444T	445	444			25.3	27.4	27.0	29.2	28	30.5	30.1	33.2	31.5	35.2	33.1	37.6	33.6	38.5
33	444T	445	444			30.1	32.3	30.5	32.6	30.7	33.2	31.3	34.4	33.8	37.6	36.9	41.6	39.4	44.4

ITEM NO.	IDENTIFICATION	ARRGT	NO. REQD.	FAN SIZE	FIG. NO.	WHEEL TYPE	CL.	PERFORMANCE						MOTOR DATA						
								CFM	O.V.	SP	R.P.M.	TEMP.	BHP	ELEV.	H.P.	R.P.M.	CURRENT	FRAME	TYPE	

ITEM NO.	MOTOR BASE	DRIVE DATA				MOTOR POS.	VIBRATION BASE TYPE	PADS TYPE	SPECIAL FEATURES
		MOTOR PULLEY	FAN PULLEY	BELTS	CENTER				

OPTIONAL ACCESSORIES

A=FLANGED INLET PUNCHED
 B=CLEANOUT DOOR-BOLTED 9 O'CLOCK
 C=CLEANOUT DOOR-QUICK CLAMP
 D=CLEANOUT DOOR-PLUG TYPE
 E=DRAIN OPENING
 F=SPECIAL FINISH-SEE NOTES
 G=SHAFT SEAL
 H=SPARK RESIST.CONST.(SEE NOTES)
 J=OUTLET DAMPER
 K=SHAFT AND BRG. GUARD
 L=HEAVY DUTY HOUSING

M=SHAFT COOLER AND GUARD
 N=INLET SCREEN
 P=HEAVY DUTY L.S. WHEEL
 Q=HORIZONTAL SPLIT HOUSING
 R=BELT GUARD
 S=EXT. GREASE FITTINGS
 T=MOUNT MOTOR & DRIVES
 U=INLET BOX
 V=INLET BOX DAMPER
 W=FLANGED OUTLET
 X=SPRAY NOZZLE 2"NPT @11 O'CLOCK

NOTES

When vibration or unitary base is furnished disregard foundation plan shown above and refer to vibration or unitary base Dwg.
 Refer to order acknowledgment for shipping details.

CUSTOMER _____

JOB NAME _____ P.O.# _____

LOCATION _____

SERIES 9000
ARRANGEMENT 1 & 9 SISW CLASS IV
FIXED DISCHARGE - SIZES 23 TO 33
SHELDONS ENGINEERING

www.sheldonsengineering.com
 sales@sheldonsengineering.com

FURNISHED FOR SALES PURPOSES-DIMENSIONS NOT CERTIFIED	DATE	SUBMITTED BY	SALES OFFICE
DRAWING CERTIFIED BY S.E. FURNISHED FOR APPROVAL-NOT RELEASED FOR PRODUCTION	DATE	ENGINEER	SO#
DRAWING CERTIFIED BY S.E. APPROVAL NOT REQUIRED-RELEASED FOR PRODUCTION	DATE	ENGINEER	DWG#

* WHEEL TYPES: X0 = Long Shavings, XB = Air/Material

POSITION OF DISCHARGE & ROTATION FROM DRIVE SIDE

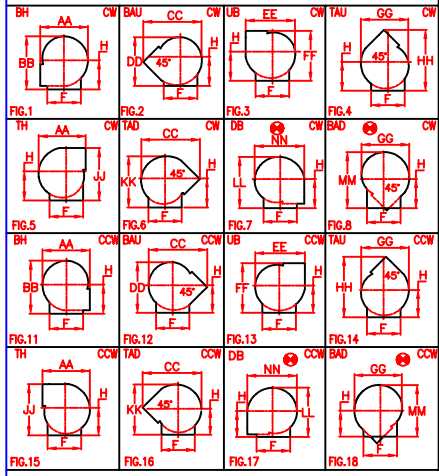

ARRANGEMENT 9 ILLUSTRATED (9L SHOWN, 9R OPP. HAND).
ARRANGEMENT 1 SAME AS ILLUSTRATED BUT WITHOUT MOTOR

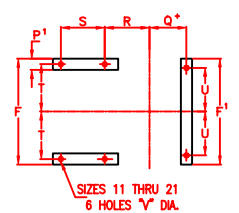
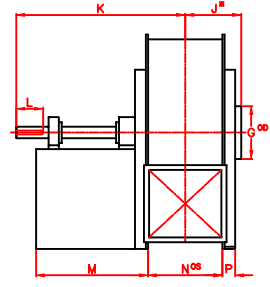
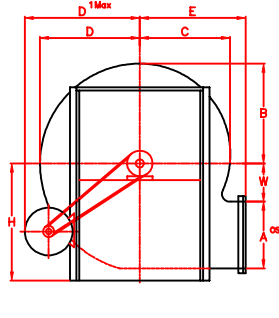

SIDE ELEVATION (drive side)

FRONT ELEVATION

FOUNDATION (plan) ▲

DIMENSIONS - INCHES (DOUBLE LETTER DIMENSIONS ARE FOR OVERALL REFERENCE ONLY)

FAN SIZE	WHEEL DIA.	SHAFT DIA.	KEYWAY SIZE	A	B	C	D	E	F	F'	G	H	K	L	M	N	P	P'	Ø
11	19 1/8	1 15/16	1/2x1/4	10 5/8	14 7/16	13 1/6	15 13/16	15	18	13 1/2	11	20	29 1/8	4 1/2	19 13/16	9 5/16	1 1/2	1 1/2	5 17/32
13	22 5/8	2 3/16	1/2x1/4	12 5/8	17 1/16	15 7/16	18 11/16	17 7/16	21	17	13	23	35 5/8	5 1/2	25 1/8	11 1/16	2	2	6 21/32
15	26 1/8	2 7/16	5/8x5/16	14 1/2	19 9/16	17 11/16	21 7/16	19 7/8	24	18 1/2	15	26	38 7/16	6	26 3/8	12 3/4	2	2	7 1/2
17	29 5/8	2 11/16	5/8x5/16	16 7/16	22 1/16	19 15/16	24 3/16	22 1/4	27	21	17	29	41 15/16	6	30 3/16	14 3/8	2	3	8 5/16
19	33	2 15/16	3/4x3/8	18 1/4	24 1/2	22 1/8	26 7/8	24 11/16	30	23	19	32	45 3/8	7	31 3/8	16	2	3	9 1/8
21	36 1/2	3 3/16	3/4x3/8	20 3/16	27 1/16	24 7/16	29 11/16	27 1/8	33 1/2	25	21	35	46 5/8	7	31 3/4	17 11/16	2	3	9 11/32

+ FOR TYPE "C" SPARK RESISTANT CONSTRUCTION 200 F AND ABOVE, ADD 3/8" TO DIMENSIONS SHOWN.

FAN SIZE	R	S	T	U	V	W	LS WHEEL*	AA	BB	CC	DD	EE	FF	GG	HH	JJ	KK	LL	MM	NN
11	8 3/32	15 3/4	8 3/8	4 1/2	1/2	6 1/16	8 3/32	30 13/16	34 7/16	38 5/8	33 3/4	32 5/8	35	30 1/4	43 1/2	38 3/16	36 1/2	35 13/16	35 1/8	31 1/8
13	9 1/32	20 3/4	9 5/8	7 1/16	5/8	7 3/16	9 7/32	36 1/8	40 1/16	45 1/4	39 1/4	38 3/8	40 7/16	35 3/4	50 7/16	44 5/16	42 1/2	41 11/16	40 7/8	36 7/8
15	8 7/8	23	11 1/8	8 3/16	5/8	8 5/16	10 1/8	41 5/16	45 9/16	51 3/4	44 5/8	43 7/8	45 7/8	41	57 1/4	50 5/16	48 3/8	47 7/16	46 1/2	42 3/8
17	11 11/16	24 5/16	12 1/4	9 3/16	5/8	9 3/8	11 1/16	46 7/16	51 1/16	58 3/16	50	49 3/8	51 1/4	46 1/4	64 1/16	56 5/16	54 1/4	53 3/16	52 1/8	47 7/8
19	12 7/8	25 1/4	13 3/4	10 1/4	5/8	10 1/2	12	51 9/16	56 1/2	64 9/16	55 5/16	54 3/4	56 11/16	51 3/8	70 7/8	62 1/4	60 1/16	58 7/8	57 11/16	53 1/4
21	13 23/32	25 5/8	15 1/2	11 1/4	5/8	11 5/8	14 1/32	56 13/16	62 1/16	71 1/8	60 3/4	60 3/8	62 1/8	56 3/4	77 3/4	68 5/16	66	64 11/16	63 3/8	58 7/8

MAXIMUM MOTOR

ARRANGEMENT 9 DRIVE CENTERS

FAN SIZE	T-FRAMES		U-FRAMES		FRAME 56		FRAME 143-145		FRAME 182-184		FRAME 213-215		FRAME 254-256		FRAME 284-286		FRAME 324-326		FRAME 364-365		
	ODP&TEFC	ODP	TEFC	MIN.	MAX.	MIN.	MAX.	MIN.	MAX.	MIN.	MAX.	MIN.	MAX.	MIN.	MAX.	MIN.	MAX.	MIN.	MAX.	MIN.	MAX.
11	215T	215	215			14.5	16.8	15.5	17.68	16.5	18.6										
13	256T	256	256			16.0	18.3	17.0	19.25	17.62	20	18.75	21.43								
15	286	286U	286U			18.0	20.43	18.75	21.0	19.25	21.87	20.0	22.87	20.43	23.56						
17	326	326	326					19.93	22.25	20.37	23.06	21.12	24.06	21.5	24.68	22.75	26.67				
19	365	365U	365U					21.37	23.87	21.87	24.6	22.5	25.56	22.81	26.25	23.62	27.43	24.5	28.75		
21	365	365U	365U									22.75	25.68	23.31	26.56	23.62	27.18	24.25	28.37	24.75	29.25

ITEM NO.	IDENTIFICATION	ARRGT	NO. REQD.	FAN SIZE	FIG. NO.	WHEEL TYPE	CL.	PERFORMANCE					MOTOR DATA									
								CFM	O.V.	SP	R.P.M.	TEMP.	BHP	ELEV.	H.P.	R.P.M.	CURRENT	FRAME	TYPE			

ITEM NO.	MOTOR BASE	DRIVE DATA				MOTOR POS.	VIBRATION BASE TYPE	PADS TYPE	SPECIAL FEATURES
		MOTOR PULLEY	FAN PULLEY	BELTS	CENTER				

OPTIONAL ACCESSORIES

- A=FLANGED INLET
- PUNCHED □ UNPUNCHED
- B=CLEANOUT DOOR-BOLTED
- C=CLEANOUT DOOR-QUICK CLAMP
- Q=CLEANOUT DOOR-PLUG TYPE
- E=DRAIN OPENING
- F=SPECIAL FINISH-SEE NOTES
- G=SHAFT SEAL
- H=SPARK RESIST.CONST.(SEE NOTES)
- J=OUTLET DAMPER
- K=HEAVY DUTY HOUSING
- L=COOLING WHEEL
- M=INLET SCREEN
- N=HEAVY DUTY L.S. WHEEL
- P=BELT GUARD
- Q=SHAFT/BEARING GUARD
- R=EXT. GREASE FITTING
- S=MOUNT MOTOR & DRIVES
- T=INLET BOX
- U=INLET BOX DAMPER
- V=PUNCHED FLANGED OUTLET DB & BAD ONLY
- W=SLIP FIT INLET

NOTES

- ⊗ Flanged outlet is not std. on DB & BAD units. When flanged outlet (punched) is required on DB (Fig.7&17) or BAD (Fig.8&18) units.
- ▲ When vibration or unitary base is furnished disregard foundation plan shown above and refer to vibration or unitary base Dwg.
- Refer to order acknowledgment for shipping details.

CUSTOMER _____

JOB NAME _____ P.O.# _____

LOCATION _____

SERIES 9000
ARRANGEMENT 1 & 9 SWSW CLASS IV
FIXED DISCHARGE - SIZES 11 TO 21
SHELDONS ENGINEERING



www.sheldonsengineering.com
sales@sheldonsengineering.com

FURNISHED FOR SALES PURPOSE DIMENSIONS NOT CERTIFIED	DATE	SUBMITTED BY	SALES OFFICE
DRAWING CERTIFIED BY S.E. APPROVAL-NOT RELEASED FOR PRODUCTION	DATE	ENGINEER	SO#
DRAWING CERTIFIED BY S.E. APPROVAL-NOT REQUIRED-RELEASED FOR PRODUCTION	DATE	ENGINEER	DWG#

* WHEEL TYPES: XO = Long Shavings, XB = Air/Material